

ABZ[®]



ABZ[®]
The consistent economic working
place system from A to Z



Table of Contents Furniture System ABZ®		Page		Page
ABZ® - Innovations		2-3		
Fields of application / Models		4-9		
ABZ-Laboratory	- for electronic laboratories	4	Aluminium rise-and-fall pendant	52
ABZ Didactic	- for training and further education	6	Flexible individual working place lamps	53
ABZ Assembly	- for manufacture and assembly	8	Point light lamps	53
Basic System Components		10-29	Fan lamps	53
Patterns		10-11	Magnifying lamps	53
Work tables with basic work top		12	Lamps for office and computer working places	53
Work tables with postforming work top		13	Perforated sheet metal walls with accessories	54
Linkable tables		14-15	Bowls, cases and tongues	55
Programme of drawer units		16-19	Supports for bowls, cases and tongues	55
Suspended drawer units		16	Visual stock boxes	56
Drawer units with rollers		17	Supports for visual stock boxes	56
Organizational elements for ABZ steel drawers		18	Swivel arm and swivel elements	57-58
Plastic drawer inserts for ABZ steel drawers		19	Storage plates, circular, documentation, cable holder	59
varantec®lock – electronic locking system		20-21	Bottle holder, hook, cable roll holder, waste paper basket	60
Aluminium leg system profile		22-24	Foot rests	60
Various profile lengths and sliding blocks		22	Energy supply for assembly working places	61-62
Possible wirings for power and data lines		23	Cable trough	61
The profile in function		24	Horizontal support for multiple connector strips	61
Storage board programme		25	Vertical aluminium energy channels	61
ABZ® system channel		26-27	ABZ® didactic system components for training	63-71
System channels		26	Experiment frames	63-65
Aluminium profile adapted to the back		27	Displaceable experiment frames	64
Functional components for aluminium profile		27	Multifunctional classrooms	66-71
Modern lighting engineering at the working place		28-29	Foldaway tables	66-67
highlight – innovative light engineering		28	Tables with swivel attachments	68-69
erfi sensolight® - the new light dimension		29	19" octagon attachments / island working places	70
Insert board programme acto®		30-39	19" pentagon attachments / island working places	70
Safety and switchgears		30	19" device racks (vertical device supports)	71
AC supplies single-phase (sockets)		31	Drawer units for training	71
Unearthed slight AC supplies single and three-phase		32	Cabinet systems for laboratory and office	72-75
AC modules		32	Cabinet systems varantec®pro and varantec®select	72-73
Regulating transformers single-phase (unearthed+earthed)		33	Basic cabinets (cabinets with drawers)	72
Solid voltage sources		34	Sideboards (cabinets with wing doors)	73
Regulating supply units, telecontrollable		35	High-level cabinets (cabinets for laboratory and office)	74-75
Functional generators		36-37	Accessories	76-82
Pneumatic supplies		38	Tables with embedded monitors and glass panels	76
RC decade		38	Tables with embedded flat screens and glass panels	76
RC and L-logade		38	Monitor swivel arm	76
Bus coupler fields		38	Monitor holder, keyboard support, keyboard clamp	76
Continuity testers		39	Flat screen swivel arm	77
Solder stations		39	Horizontal support rail for flat screens	77
Ring circuit panels / data and telephone sockets		39	Measuring line holders, hose holders etc.	78
Interface panels		39	Cable trolleys	78
Empty panels		39	Working mats, not conductive	78
ABZ® Laboratory System Components for electronics		40-45	Laboratory cables, BNC cables, measuring accessories	79
Energy attachments (for insert board programme acto®)		40	EGB working place equipment	80
Energy cockpits (for insert board programme acto®)		41	Conductive working and floor mats	80
19" Device attachments (19" devices highlab and basic)		42	Solid rubber lattice mats	81
DINA4 attachments and DINA4 cockpits		43	Earthing modules, safety wrist strap	81
19" Device cockpits (for 19" devices highlab and basic)		44-45	Spiral cables	81
ABZ® Assembly – System components for assembly		46-62	Spannfix articulated standing vise	82
Height adjustable working places		46	Programme of seats	83-87
ABZ lifeline–variable working heights, manual+motorized		46	Visitor chairs Leanos	83
Material and assembly trolleys		47	Laboratory chairs Leanos	84
Side tables		48-49	Cloth covers	85
Universal assembly extension arms		50	Working charis Sintec	86
Rails with tool trolleys		50	Wooden swivel chairs, swivel stools, standing assistants	87
Compressed air supply systems		50-51	Index	88-89
Universal compressed air supp rail		50	Alphabetical index	88-89
Balancer		51		
Compressed air spirial hose		51		
Lighting systems for the assembly world		51-53		
Aluminium swivel lamps		51		

ABZ[®]

The consistent economic working place system
from A to Z



ABZ® Working place systems for technology and technical communication

The system ABZ has been completely newly developed. Due to this consistent development a further innovation push has been achieved.

The adaptation of the innovative aluminium profiles to the back converts the new ABZ system to a multipurpose system

and climbs in the league of the aluminium systems.

With the new ABZ furniture system erfi emphasizes once again its extraordinary innovative power and prominent market position in the field of technical working place systems.

The highlights of this offensive model series are of advantage in all departments of the company.

Many advantages of the revolutionary table system varantec® are now also deliverable with the new ABZ system and are decisive for the extraordinary high functionality.

ABZ® – Innovations



highlight – The innovative lighting technology – your eyes will appreciate it !

An active illumination grid guarantees non-glaring work tops, almost independently of the installation height. The light beams are regularly distributed by the active illumination grid. The anodized surface brightens the working area even more. Therefore, the inclination of the lamp is not necessary. Amongst the 8 highlight basic designs you will definitely find your optimal lamp (see page 28)

highlight – A unique technique, only offered by erfi.



erfi sensolight® - The revolution of the sensor-controlled light

Contactless switching on and off of the light sources, sensors for presence for the automatic light control and fully automatic regulation of the light volume depending on the ambient light (registered design No. 202 05 736 4) (see page 29)

erfi sensolight® - An erfi innovation.



ABZ®-lock - The keyless evolution

The security and comfort of electronic locking systems may not stop behind the door. The technology already known in the furniture system varantec has now been integrated in the ABZ system. By means of infrared or radio transmitters all erfi furniture components can be opened and closed electronically without contact. (see page 20 and 21)

ABZ-lock – An erfi innovation.



ABZ®- liftline - The solution for height adjustable work tops

Variable working height by means of clamp connections or electrohydraulic height adjustment and adjustment by a crank leave nothing to be desired. Maintenance-free due to elegant and appropriate hydraulic cylinders in the table legs, ensuring a maximum service life and simultaneously a maximum solidity regarding vibrations. (see page 46).

ABZ – lift – The modern height adjusting technique – exclusively from erfi !



ABZ®-Laboratory - The new model series for laboratory, development, service and testing

This model series with energy attachments, 19 inch device attachments and device cockpits offer an almost inexhaustible variety and always sufficient space for installing the erfi programme acto®, basic and highlab. The solid and welded basic design gives the necessary stability. All table legs are welded with the basic frame. (no bolted legs).

ABZ – Laboratory – A superior and representative system with excellent qualities.



ABZ®-Assembly - The new model series for manufacture and assembly

The ABZ-Assembly has the same platform as ABZ-Laboratory. Numerous system components guarantee an optimal functionality in the field of manufacture and assembly. Due to the aluminium extruded profiles adapted to the back, all advantages of an aluminium system are used.

The completely newly developed profile with its 6 grooves guarantees a perfect connection and adjustment with all imaginable system components.

ABZ - Assembly - The design of the aluminium assembly table system is convincing by many new aspects. The lateral aero-color perforated plates with a modern surface provide a pleasant freshness in the world of net product.



ABZ®-Didactic - The new model series for training and further education

ABZ-Didactic has been developed for vocational schools, technical colleges, universities, chamber of handicrafts, colleges, educational technological centres, for all technical training centres as well as for apprenticeship companies.

Training islands with multi-corner attachments, electric motor-driven foldaway tables and swivelling tables for a multi-functional training as well as for the integration of the screens leave nothing to be desired already during the planning phase.

ABZ-Didactic – A system which gives freedom for developing creativity.

Working place system for laboratory, development, service and testing

ABZ-Laboratory is a model series which provides all necessary system components in the fields of electric engineering and electronics.

The device attachments and device cockpits:

1. Energy attachments and energy cockpits for installing the efficient programme of insert boards acto®
2. 19 inch device attachments and device cockpits for installing the 19 inch device system basic and highlab
3. 19 inch combine attachments and combined cockpits for installing the 19 inch device system basic and highlab as well as the programme of insert boards acto®
4. DINA4 attachments and DINA4 cockpits for installing the DINA4 files



As an alternative to the modern aluminium profile system which is adaptable to the back, all shelves and device cockpits are deliverable with an add-on table attachment.

The new ABZ® Aluminium profile system

The aluminium profile system at the back provides new functionality regarding connection and cable management.

19 inch device cockpits, shelves and other system components are flexibly adaptable and steplessly adjustable in height by their grooves.

Power and data lines can be placed elegantly and invisibly in the groove of the device cockpits. The grooves are covered by a clip profile.

For more extensive cabling, additional channels are available which, as per requirement, can be adapted directly to the ABZ aluminium profile system.

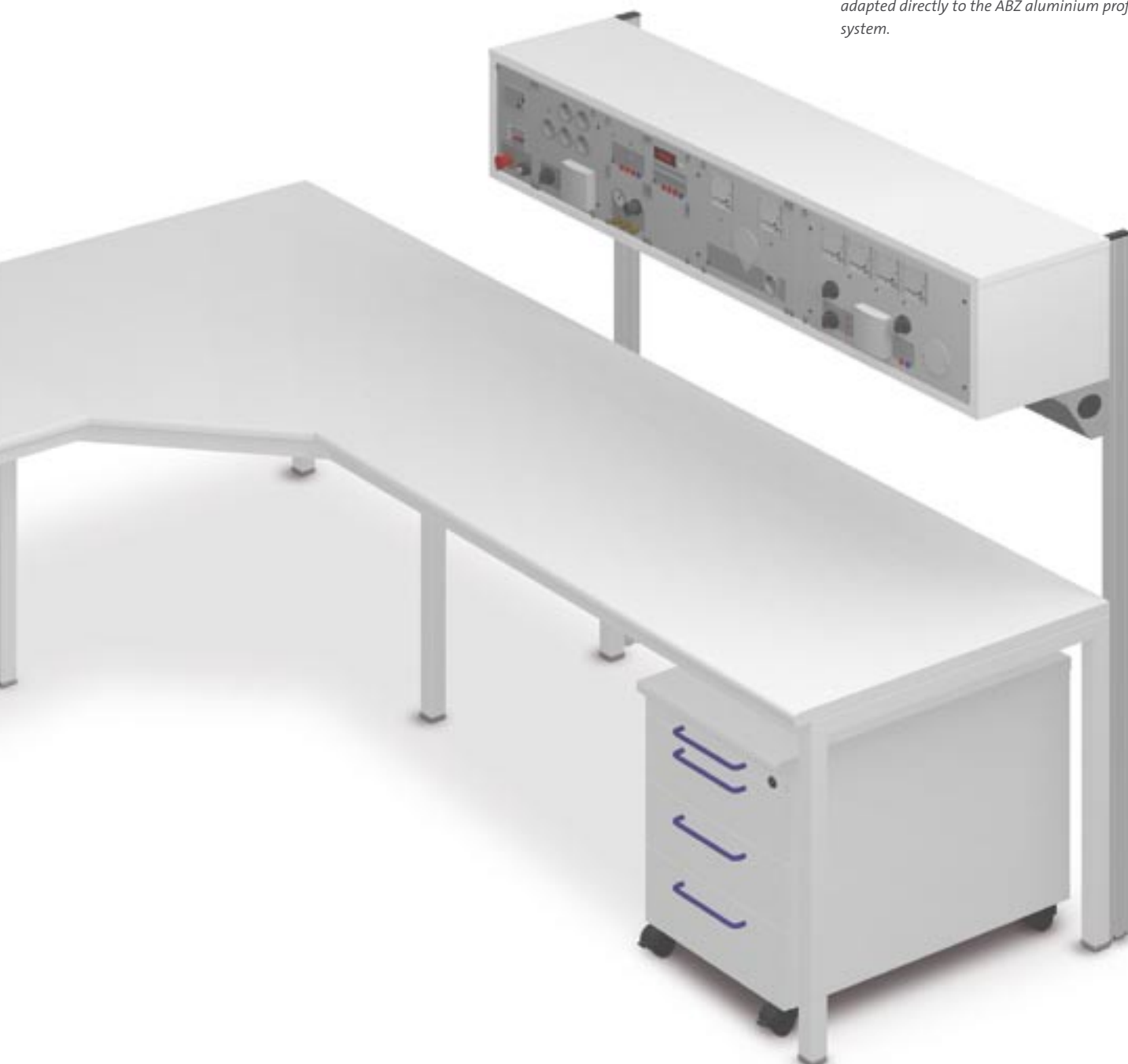

Working place system for training and further education

erfi as a leading manufacturer for all technical professions has extended its laboratory furniture system ABZ by Didactic standard system components. The new Didactic components meet all requirements in the field of training and further education.

Vocational schools and technical colleges, training centres of all kinds, chamber of handicrafts, vocational academies, training colleges, technical colleges and universities are equally equipped with the modern system components from erfi as training centres in big companies.





Working place system for manufacture and assembly

ABZ-Assembly offers an enormous variety of standardized system components in the field of assembly.

At the back the programme has a solid aluminium profile with 6 grooves. All system components for assembly can be adapted accurately.

System components such as extension arms, lamps, rails, shelves and energy supplies are only a few examples of the ABZ assembly world.

The system offers height adjustment by clamp connections, cranks and motorized drives as well as the integration of transfer systems in the table tops.

ABZ-Assembly is an absolutely vibration-free 4-leg table system which allows many configurations and extensions.



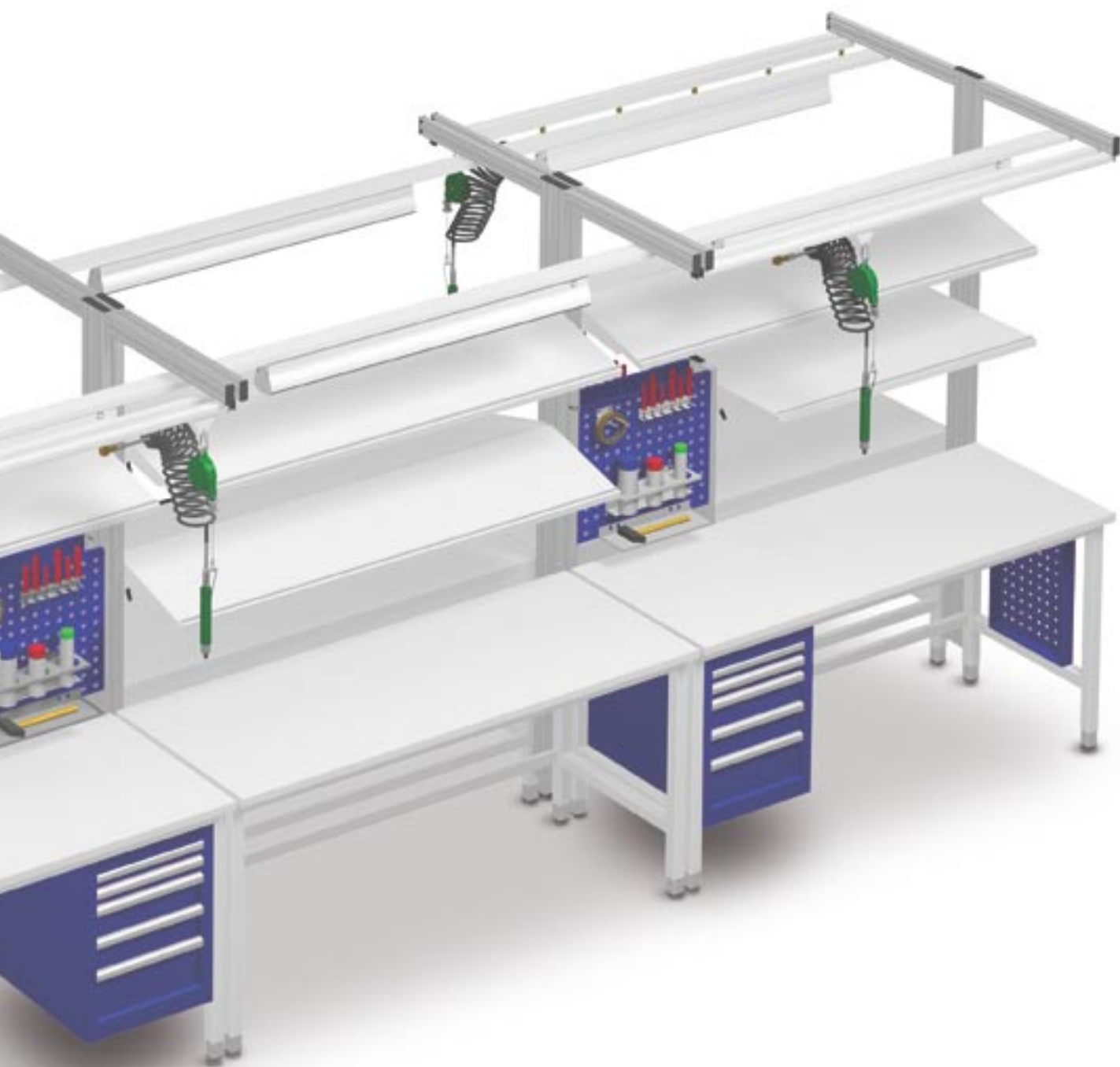

The new ABZ® System offers 10 modern and up-to-date patterns

The combination between four decorative surfaces and four colours of the frames give the system new freshness

Selection of patterns for ABZ work tops

not conductive light-gray	volume conduc- tive EBG/ESD design light-gray	decorative maple surface for office and communica- tion	decorative beech surface for office and communica- tion
------------------------------	---	--	--

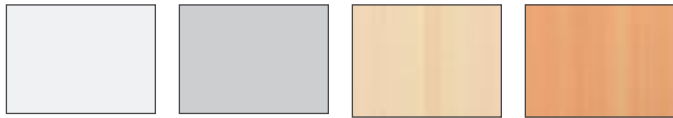

Selection of patterns for ABZ steel frames

light-gray, similar to RAL 9002 pref- erential colour	aluminium-white RAL 9006 alter- natively available	black-gray RAL 7021 alternatively available	gentian-blue RAL 5010 alterna- tively available
---	--	---	---



Not conductive patterns pull for drawers: alternatively to bow-type handle



Dekor 1 (*):
Work top: light-gray
Attachment: light-gray
Drawer unit: light-gray
Steel frame: light-gray
Bow-type handle: light-blue
(Pull: light-gray)

Dekor 2 (*):
Work top: light gray
Attachment: light-gray
Drawer unit: light-gray
Steel frame: white aluminium
Bow-type handle: white aluminium
(Pull: light gray)

Dekor 3 (*):
Work top: light-gray
Attachment: light-gray
Drawer unit: light-gray
Steel frame: black-gray
Bow-type handle: black-gray
(Pull: black-gray)

Dekor 4 (*):
Work top: light-gray
Attachment: light-gray
Drawer unit: light-gray
Steel frame: gentian-blue
Bow-type handle: gentian-blue
(Pull: light-gray)

Conductive Patterns pull for drawers: alternatively to bow-type handles



Dekor 5 ():**
Work top: light-gray
conductive
Attachment: light-gray
Drawer unit: light-gray
Steel frame: light-gray
Pull: light gray
(Bow-type handle: light-blue)

Dekor 6 ():**
Work top: light gray
conductive
Attachment: light-gray
Drawer unit: light-gray
Steel frame: white aluminium
Pull: light-gray
(Bow-type handle: white aluminium)

Dekor 7 ():**
Work top: light-gray
conductive
Attachment: light-gray
Drawer unit: light-gray
Steel frame: black-gray
Pull: black-gray
(Bow-type handle: black-gray)

Dekor 8 ():**
Work top: light-gray
conductive
Attachment: light-gray
Drawer unit: light-gray
Steel frame: gentian-blue
Pull: light-gray
(Bow-type handle: gentian-blue)

On request all system components such as attachments and drawer units are also available of conductive design!

(*) Figures for pattern 1 to 4 with bow-type handles, alternatively with pulls.

(**) Figures for pattern 5 to 8 with pulls, alternatively with bow-type handles.



Pattern 9:

Work top: maple
 Attachment: maple
 Drawer unit: maple
 Steel frame: white aluminium
 Bow-type handle: chromium-plated
 (Pulls are not recommended for this pattern)

Technical Data:

Work top not conductive



Cross section

Raw chipboard, chipboard with a thin chipboard top as per DIN EN 312 CE
 Decorative side with 0,8 mm brilliant HPL, as per DIN EN 438.
 Technical value as per DIN EN 312.

Chemical resistance: against organic solvents, slight acids and lye, benzine and oil, as per DIN 53799
 Temperature resistance: short-term 180° C
 Raw density: approx. 650 kg/m³
 Edges: plastic light-gray, maple or beech



Dekor 10:

Work top: beech
 Attachment: beech
 Drawer unit: beech
 Steel frame: white aluminium
 Bow-type handle: chromium-plated
 (Pulls are not recommended for this pattern)

Technische Daten:

Arbeitsplatte volumenleitfähig EGB/ESD-Ausführung



Querschnitt

Raw chipboard ESA, raw chipboard allowing electro-static discharge with a thin chipboard top as per DIN EN 61340-5 part 1 and 2 (volume conductive) Decorative side with 0,8 mm brilliant HPL, as per DIN EN 438. Technical value as per DIN EN 312.

Chemical resistance: against organic solvent, slight acids and lye, benzine and oil, as per DIN 53799
 Temperature resistance: short-term 180° C
 Earth connection resistance: 7,5E5 to 1E10 Ohm
 Raw density: approx. 650 kg/m³
 Edges: plastic light-gray

Deviations in colour of the illustrations may be due to the print

Work tables with a basic top

Table top:

30 mm thick, with a plastic edge banding all around

Frame:

profile pipe, solidly welded, optionally with welded-on or screwed-on legs.

Table height:

780 mm, other table heights deliverable on request

Option:

Reinforcement of the lower frame

Selection of pattern:

See page 10-11



The reinforcement of the lower frame is available as an option



ABZ offers the additional variant with a table top projecting by 45 mm at the front

Table top flush at the front						Table top projecting by 45 mm at the front					
		Completely assembled with welded legs		Pre-assembled for self-assembly				Completely assembled with welded legs		Pre-assembled for self-assembly	
Width	Depth	Order-No.	Order-No. conductive	Order-No.	Order-No. conductive	Width	Order-No.	Order-No. conductive	Order-No.	Order-No. conductive	
1200	600	04.1.1261	04.1.1262	04.1.1263	04.1.1264	645	04.1.1265	04.1.1266	04.1.1267	04.1.1268	
	800	04.1.1281	04.1.1282	04.1.1283	04.1.1284	845	04.1.1285	04.1.1286	04.1.1287	04.1.1288	
	900	04.1.1291	04.1.1292	04.1.1293	04.1.1294	945	04.1.1295	04.1.1296	04.1.1297	04.1.1298	
	1000	04.1.1211	04.1.1212	04.1.1213	04.1.1214	1045	04.1.1215	04.1.1216	04.1.1217	04.1.1218	
1600	600	04.1.1661	04.1.1662	04.1.1663	04.1.1664	645	04.1.1665	04.1.1666	04.1.1667	04.1.1668	
	800	04.1.1681	04.1.1682	04.1.1683	04.1.1684	845	04.1.1685	04.1.1686	04.1.1687	04.1.1688	
	900	04.1.1691	04.1.1692	04.1.1693	04.1.1694	945	04.1.1695	04.1.1696	04.1.1697	04.1.1698	
	1000	04.1.1611	04.1.1612	04.1.1613	04.1.1614	1045	04.1.1615	04.1.1616	04.1.1617	04.1.1618	
1800	600	04.1.1861	04.1.1862	04.1.1863	04.1.1864	645	04.1.1865	04.1.1866	04.1.1867	04.1.1868	
	800	04.1.1881	04.1.1882	04.1.1883	04.1.1884	845	04.1.1885	04.1.1886	04.1.1887	04.1.1888	
	900	04.1.1891	04.1.1892	04.1.1893	04.1.1894	945	04.1.1895	04.1.1896	04.1.1897	04.1.1898	
	1000	04.1.1811	04.1.1812	04.1.1813	04.1.1814	1045	04.1.1815	04.1.1816	04.1.1817	04.1.1818	
2000	600	04.1.2061	04.1.2062	04.1.2063	04.1.2064	645	04.1.2065	04.1.2066	04.1.2067	04.1.2068	
	800	04.1.2081	04.1.2082	04.1.2083	04.1.2084	845	04.1.2085	04.1.2086	04.1.2087	04.1.2088	
	900	04.1.2091	04.1.2092	04.1.2093	04.1.2094	945	04.1.2095	04.1.2096	04.1.2097	04.1.2098	
	1000	04.1.2011	04.1.2012	04.1.2013	04.1.2014	1045	04.1.2015	04.1.2016	04.1.2017	04.1.2018	
Reinforcement of the frame at the side and at the back				04.1.3000		4 pcs. V2A leg sliders for EGB tables instead of a discharge connection			04.1.3100		

Work tables with postforming table top

Table top:

30 mm thick, with an ergonomically designed postforming edge. Surface HPL laminate.

Frame:

profile pipe, solidly welded, optionally with welded-on or screwed-on legs.

Table height:

780 mm, other table height deliverable on request.

Option:



Reinforcement of the lower frame

Selection of pattern:

See page 10-11



The reinforcement of the lower frame is available as an option

		Completely mounted with a welded frame		Pre-assembled for self-assembly	
Width	Depth	Order No.	Order No.  conductive	Order No.	Order No.  conductive
1200	645	04.2.1261	04.2.1262	04.2.1263	04.2.1264
	845	04.2.1281	04.2.1282	04.2.1283	04.2.1284
	945	04.2.1291	04.2.1292	04.2.1293	04.2.1294
	1045	04.2.1211	04.2.1212	04.2.1213	04.2.1214
1600	645	04.2.1661	04.2.1662	04.2.1663	04.2.1664
	845	04.2.1681	04.2.1682	04.2.1683	04.2.1684
	945	04.2.1691	04.2.1692	04.2.1693	04.2.1694
	1045	04.2.1611	04.2.1612	04.2.1613	04.2.1614
1800	645	04.2.1861	04.2.1862	04.2.1863	04.2.1864
	845	04.2.1881	04.2.1882	04.2.1883	04.2.1884
	945	04.2.1891	04.2.1892	04.2.1893	04.2.1894
	1045	04.2.1811	04.2.1812	04.2.1813	04.2.1814
2000	645	04.2.2061	04.2.2062	04.2.2063	04.2.2064
	845	04.2.2081	04.2.2082	04.2.2083	04.2.2084
	945	04.2.2091	04.2.2092	04.2.2093	04.2.2094
	1045	04.2.2011	04.2.2012	04.2.2013	04.2.2014
Reinforcement of the frame at the side and at the back		04.1.3000	V2A leg sliders for EGB tables instead of a discharge connection		04.1.3100

Linkable tables

ABZ linkable tables are the precondition for an optimal interior design from an architectural and working point of view. The design principally corresponds to the basic types of table.

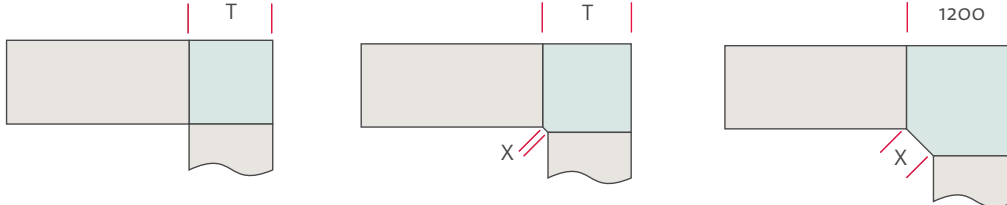

Depth of table	Design	Basic board		Postforming			Basic board		Postforming	
		Order No.	T mm	Order No.	T mm	X mm	Order No.	X mm	Order No.	X mm
600	Standard	04.1.4161	600	04.2.4161	675	42	04.1.4261	849	04.2.4261	785
600	EGB	04.1.4162	600	04.2.4162	675	42	04.1.4262	849	04.2.4262	785
800	Standard	04.1.4181	800	04.2.4181	875	42	04.1.4281	566	04.2.4281	502
800	EGB	04.1.4182	800	04.2.4182	875	42	04.1.4282	566	04.2.4282	502
900	Standard	04.1.4191	900	04.2.4191	975	42	04.1.4291	424	04.2.4291	361
900	EGB	04.1.4192	900	04.2.4192	975	42	04.1.4292	424	04.2.4292	361
1000	Standard	04.1.4111	1000	04.2.4111	1075	42	04.1.4211	283	04.2.4211	219
1000	EGB	04.1.4112	1000	04.2.4112	1075	42	04.1.4212	283	04.2.4212	219

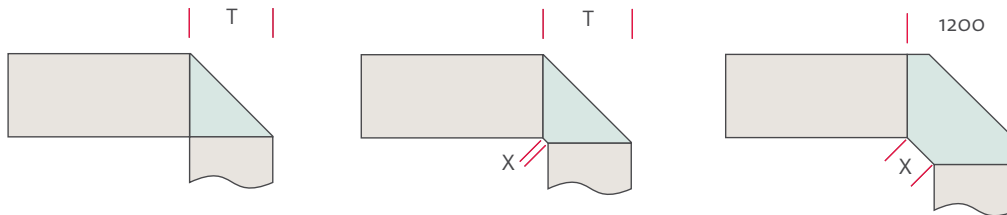

Depth of table	Design	Basic board		Postforming			Basic board		Postforming	
		Order No.	T mm	Order No.	T mm	X mm	Order No.	X mm	Order No.	X mm
600	Standard	04.1.5161	600	04.2.5161	675	42	04.1.5261	849	04.2.5261	785
600	EGB	04.1.5162	600	04.2.5162	675	42	04.1.5262	849	04.2.5262	785
800	Standard	04.1.5181	800	04.2.5181	875	42	04.1.5281	566	04.2.5281	502
800	EGB	04.1.5182	800	04.2.5182	875	42	04.1.5282	566	04.2.5282	502
900	Standard	04.1.5191	900	04.2.5191	975	42	04.1.5291	424	04.2.5291	361
900	EGB	04.1.5192	900	04.2.5192	975	42	04.1.5292	424	04.2.5292	361
1000	Standard	04.1.5111	1000	04.2.5111	1075	42	04.1.5211	283	04.2.5211	219
1000	EGB	04.1.5112	1000	04.2.5112	1075	42	04.1.5212	283	04.2.5212	219

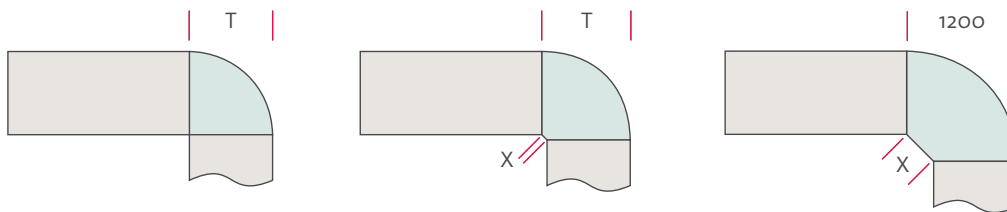

Depth of table	Design	Basic board		Postforming			Basic board		Postforming	
		Order No.	T mm	Order No.	T mm	X mm	Order No.	X mm	Order No.	X mm
600	Standard	04.1.6161	600	04.2.6161	675	42	04.1.6261	849	04.2.6261	785
600	EGB	04.1.6162	600	04.2.6162	675	42	04.1.6262	849	04.2.6262	785
800	Standard	04.1.6181	800	04.2.6181	875	42	04.1.6281	566	04.2.6281	502
800	EGB	04.1.6182	800	04.2.6182	875	42	04.1.6282	566	04.2.6282	502
900	Standard	04.1.6191	900	04.2.6191	975	42	04.1.6291	424	04.2.6291	361
900	EGB	04.1.6192	900	04.2.6192	975	42	04.1.6292	424	04.2.6292	361
1000	Standard	04.1.6111	1000	04.2.6111	1075	42	04.1.6211	283	04.2.6211	219
1000	EGB	04.1.6112	1000	04.2.6112	1075	42	04.1.6212	283	04.2.6212	219

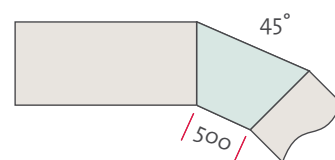
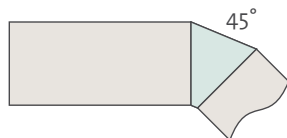

Depth of table	Design	Basic board Order No.	Postforming Order No.	Basic board Order No.	Postforming Order No.
600	Standard	04.1.8161	04.2.8161	04.1.8261	04.2.8261
600	EGB	04.1.8162	04.2.8162	04.1.8262	04.2.8262
800	Standard	04.1.8181	04.2.8181	04.1.8281	04.2.8281
800	EGB	04.1.8182	04.2.8182	04.1.8282	04.2.8282
900	Standard	04.1.8191	04.2.8191	04.1.8291	04.2.8291
900	EGB	04.1.8192	04.2.8192	04.1.8292	04.2.8292
1000	Standard	04.1.8111	04.2.8111	04.1.8211	04.2.8211
1000	EGB	04.1.8112	04.2.8112	04.1.8212	04.2.8212

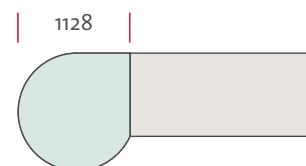
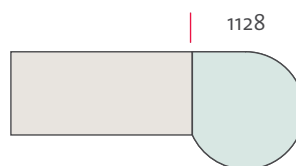
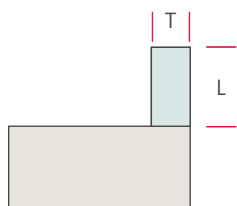

Depth of table L	Depth of table T	Design	Basic board Order No.
800	400	Basis	04.1.7841
800	400	Basis EGB	04.1.7842
800	600	Basis	04.1.7861
800	600	Basis EGB	04.1.7862
1000	600	Basis	04.1.7161
1000	600	Basis EGB	04.1.7162

Depth of table	Design	Basic board Order No.	Basic board Order No.
800	Standard	04.1.9181	04.1.9281
800	EGB	04.1.9182	04.1.9282
900	Standard	04.1.9191	04.1.9291
900	EGB	04.1.9192	04.1.9292
1000	Standard	04.1.9111	04.1.9211
1000	EGB	04.1.9112	04.1.9212

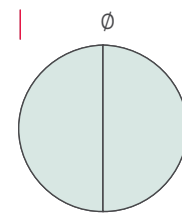
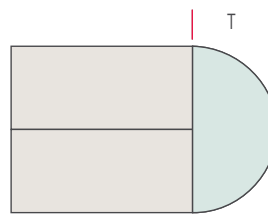
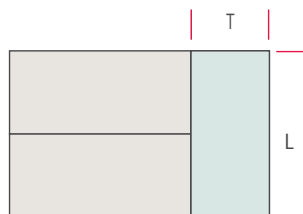

Depth of table	Design	Basic board Order No.	L mm	T mm	Basic board Order No.	T mm	Basic board Order No.	ø mm
800	Standard	04.1.0181	1600	800	04.1.0281	800	04.1.0381	1600
800	EGB	04.1.0182	1600	800	04.1.0282	800	04.1.0382	1600
900	Standard	04.1.0191	1800	900	04.1.0291	900	04.1.0391	1800
900	EGB	04.1.0192	1800	900	04.1.0292	900	04.1.0392	1800
1000	Standard	04.1.0111	2000	1000	04.1.0211	1000	04.1.0311	2000
1000	EGB	04.1.0112	2000	1000	04.1.0212	1000	04.1.0312	2000

Suspended drawer units

- Equipped with well-arranged drawers.
- Top drawer equipped in series with a high-quality insert for writing utensils.
- Front height 1 HE (HE = height unit, 1 HE = 50 mm)
- Front height of drawers from 2 HE to 7 HE



On request bow-type handles are available against extra charge



Drawer fronts of standard design with pulls

„x“ please replace by 1 or 2

1 = non-conductive patterns (light-gray, maple or beech)

2 = conductive pattern (light-gray – EGB/ESD design)

Dept of drawer unit Usable depth



580	490	04.3.1065.x	04.3.2065.x	04.3.3065.x	04.3.4065.x
780	490	04.3.1085.x	04.3.2085.x	04.3.3085.x	04.3.4085.x
780	690	04.3.1087.x	04.3.2087.x	04.3.3087.x	04.3.4087.x
880	490	04.3.1095.x	04.3.2095.x	04.3.3095.x	04.3.4095.x
880	690	04.3.1097.x	04.3.2097.x	04.3.3097.x	04.3.4097.x
980	490	04.3.1105.x	04.3.2105.x	04.3.3105.x	04.3.4105.x
980	690	04.3.1107.x	04.3.2107.x	04.3.3107.x	04.3.4107.x

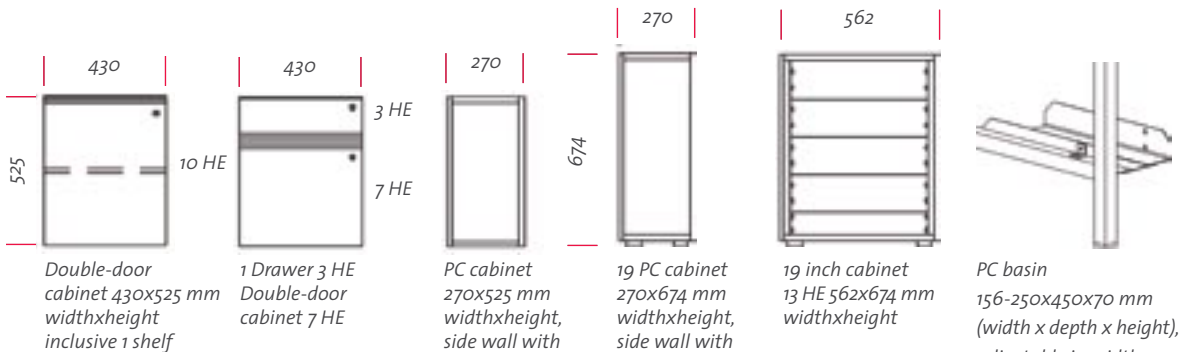

Dept of drawer unit					
580	04.3.5060.x	04.3.6060.x	04.3.7060.x	04.3.7160.x	04.3.8160.x
780	04.3.5080.x	04.3.6080.x	04.3.7080.x	04.3.7180.x	04.3.8180.x
880	04.3.5090.x	04.3.6090.x	04.3.7090.x	04.3.7190.x	04.3.8190.x
980	04.3.5100.x	04.3.6100.x	04.3.7100.x	04.3.7200.x	04.3.8200.x

Order No. 04.3.9001
Assembly position at the right
Order No. 04.3.9002

Drawer units with rollers

- Range of movable drawer units
- Equipped with well-arranged drawers
- Stop-control-plus function (security against unintentional opening which cannot be outwitted)
- Top drawer as a standard with a high-quality insert for writing utensils
- Front height 1 HE (HE = height unit, HE = 50 mm)
- Front height of drawers from 2 HE to 7 HE



On request bow-type handles are available against extra charge

Drawer fronts

of standard design with pulls

„x“ please replace by 1 or 2

1 = non-conductive patterns
(light-gray, maple or beech)

2 = conductive patterns 
(light-gray – EGB/ESD design)

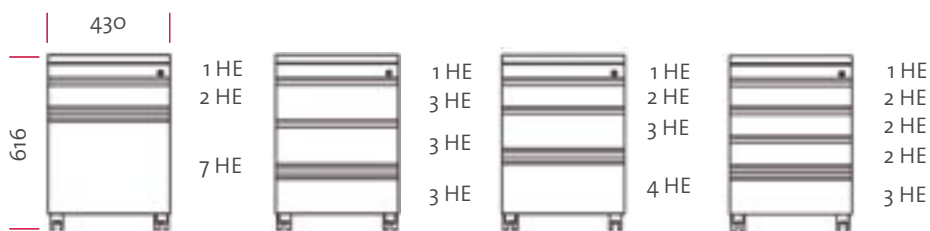

Dept of drawer unit	Usable depth of drawer				
573 mm	490 mm	04.4.1054.x	04.4.2054.x	04.4.3054.x	04.4.4054.x
773 mm	490 mm	04.4.1074.x	04.4.2074.x	04.4.3074.x	04.4.4074.x
773 mm	690 mm	04.4.1076.x	04.4.2076.x	04.4.3076.x	04.4.4076.x

Options

Full drawer extension	per drawer	04.4.0001
Main locking mechanism	per locking cylinder	04.4.0004
Main key	per piece	04.4.0005
Spare key	per piece	04.4.0006
Spare key	for main locking mechanism per piece	04.4.0007
Spare main key	per piece	04.4.0008
Leading-in cable box	Ø 50 mm	04.4.0009
Leading-in cable box	Ø 70 mm	04.4.0010
Leading-cable box	Leading-cable box PG 48, Ø 50 mm for 19"	04.4.0011

Organizational elements for steel drawers: Compartment dividers



Article	Size	Order No.
Divider double-walled with a lateral catch for the safe locking in the side wall	Steel powder-coated black	327 x 10 x 76 mm V 6.8.102
	Plastic black	327 x 10 x 76 mm V 6.8.103
Compartment divider	A4 = 310 x 1 x 72 mm	V 6.8.104
	Steel powder-coated black	A5 = 220 x 1 x 72 mm V 6.8.105
		A6 = 150 x 1 x 72 mm V 6.8.107
		A7 = 110 x 1 x 72 mm V 6.8.106



Article	Size	Order No.
Article Filing compartment for forms, angle adjustable Plastic black - for a proper filing of DIN A4 pages	Filing compartment 6-fold consisting of: - 6 files for forms - 4 dividers	V 6.8.301
	for drawers of a usable width of 327 mm, usable depth 490 or 690 resp. and a width of the drawer unit of 430 mm	



Filing compartment 11-fold consisting of: - 11 files for forms - 8 dividers for drawers	V 6.8.302
for drawers of a usable width of 327 mm, usable depth 690 mm and a width of the drawer unit of 430 mm	



Article	Size	Order No.
Article Suspension frame nickle-plated steel, plastic black - for suspending DIN A4 files - front height of drawer 7 HE - inclusive separators (1 with a usable drawer depth 490 mm) (2 usable drawer depth 690 mm)	for a usable size of 327 mm and a width of the drawer unit of 430 mm	Usable depth of drawer 490 mm V 6.8.305
		Usable depth of drawer 690 mm V 6.8.306







Article	Size	Order No.
Stamp holder powder-coated black - for 8 stamps and date stamp	327 x 110 x 30 mm (width of drawer unit 430 mm)	V 6.8.307



Displaceable insert for writing utensils plastic black - to be inserted in the steel drawer	V 6.8.309
---	-----------

Organizational elements for steel drawers: Plastic drawer inserts

Article	Material	Size	Order No.
  <p>Compartment dividers (2 pcs. required) with lateral catches for the safe locking in the side wall</p>	Steel, powder-coated black	327 x 65 x 78 mm	V 6.8.202
 <p>Swinging sheet metal plate to be inserted in 2 dividers</p>	Steel, powder-coated black	A4 quer = 317 x 1 x 210 mm A5 quer = 227 x 1 x 148 mm A6 quer = 167 x 1 x 105 mm	V 6.8.203 V 6.8.204 V 6.8.205
 <p>Example: Order No. V6.8.403</p>			

Plastic drawer inserts help to properly store small items and tools. Suitable for a usable drawer depth of 490 mm, 6 inserts and 1 supplementary insert for a usable drawer depth of 690 mm are available.

Article	Width of drawer unit	Size	Order No.
 <p>Drawer insert - with 3 compartments - for tools</p>	430 mm	327 x 490 x 40 mm	V 6.8.401
 <p>Drawer insert - with 34 compartments - for tools</p>	430 mm	327 x 490 x 40 mm	V 6.8.402
 <p>Drawer insert - with 6 compartments - for tools</p>	430 mm	327 x 490 x 40 mm	V 6.8.403
 <p>Drawer insert - with 8 compartments - for tools</p>	430 mm	327 x 490 x 40 mm	V 6.8.404
 <p>Drawer insert - 2 partitions - with totally 30 compartments - for small items</p>	430 mm	327 x 490 x 40 mm	V 6.8.405
 <p>Drawer insert - 2 partitions - with totally 25 compartments - for small items</p>	430 mm	327 x 490 x 40 mm	V 6.8.406
 <p>Supplementary insert - for a usable drawer depth of 690 mm - with 3 compartments</p>	430 mm	327 x 200 x 40 mm	V 6.8.407

The keyless evolution ABZ®-lock

Infrared transmitter



Radio transmitter (transponder)



The security and comfort of electronic locking systems may not stop behind the door. Consequently, the safety locking system ABZ-lock in the digital locking and organization systems of the building technique is of almost unlimited advantage to the user. ABZ-lock is a comprehensive electronic locking system. The system is available in two variants:

ABZ®-lock – design variants

1. Electronic locking system with infrared technology. This system is mainly used for facilities for which the previous building management does not have an electronic locking system.
2. Electronic locking system with radio technology. Nowadays new buildings are already equipped with electronic locking systems. By means of ABZ-lock the entire furniture can be included in the electronic locking plan of the buildings's management.

All lockable erfi furniture system components can be equipped with the innovative ABZ-lock technique:

- Complete cabinet systems varantec pro and varantec-select
- Complete drawer unit programme

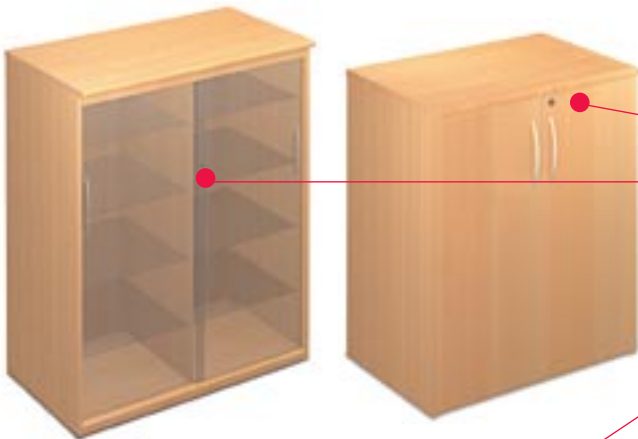

Advantages of the electronic locking system:

- Infinite locking system which allows to realize easily also complex structures
- Opening and locking by the push of a button
- Minimum administrative work due to a simple programming
- When changing the personnel or when moving, no complicated ordering of new keys but only a simple reprogramming necessary
- Loss of a key without loss of security: Immediate blocking possible. This saves consequential costs!
- Cableless due to an internal current supply, also suitable for sliding drawer units
- Audible warning signals in case of diminishing battery voltage
- Visible indication of locking and unlocking processes
- The programming is maintained even without energy supply
- Batteries which are common on the market, simple battery change
- Long service life of the batteries, 2 years for tenfold operation per day
- With radio technology: Individual transponders can be permitted or blocked resp. for individual time spans

The technology – the system

ABZ-lock comprises a few modular units: A transponder and an infrared transmitter resp. which on the push of a button activates an electronic control module which in turn releases the motorised locking mechanisms to either unlock the piece of furniture or to lock it. The electronic control module is the same for all furniture system components.

With the infrared technology there is an optical unit for the correct interaction between transmitter and receiver. At the same time the correct locking is signaled to the user in red and the correct unlocking in green. The optical unit is inserted in the front of the piece of furniture.

Different locking mechanisms are adapted to the type of locking of the piece of furniture. The locking mechanisms are coupled with the electronic control module. An intelligent technique which is a must for a new investment.

ABZ®-lock with infrared technology/programming

The programming of the individual furniture components can be made in all cases without additional hardware or software. As with normal key-operated lockings there is a difference between locking with and without main or general key-operated locking systems.

Electronic locking for individual pieces of furniture without a main or general locking system resp. (basic programming)

The lock is simply programmed with a stick and a transmitter. By inserting the stick in the electronic control module, the programming mode is activated (teach-in mode). By simply operating the transmitter the same is trained. In this way up to 100 different transmitters per lock can be programmed.

Each transmitter is unique. Several billions of different transmitters render this system untouchable. In case of the loss of a transmitter, a new transmitter can be trained very quickly. Everything can be deleted and trained again by an integrated reset button.

Locking systems for facilities with a main or general locking system (comfort programming)

With this comfortable locking an additional blue programming transmitter is supplied for the complete locking system. For the blue transmitter a conventional safety certificate is issued. In case of loss the programming transmitter can be reproduced against presentation of this safety certificate. The purpose of this programming transmitter is to put all control modules of the locking system into programming mode.



Optical unit for the infrared technology



Electronic control module



Example of the locking mechanism



If a control module is in programming mode, the individual transmitters can be trained and deleted without contact. In this way complete main and general locking systems can be programmed on site.

With this variant programming itself can easily be done from outside.

Article		Order No.
Electronic locking	Sliding door	04-7-301
	Roll shutters	04-7-302
	Double doors	04-7-303
	Drawers	04-7-304
Infrared transmitter casing black, as an option chromium-plated		04-7-305
Spare programming stick (1 pc. per locking system is included as a standard)		04-7-306
Programming transmitter casing blue (comfortable contactless design)		04-7-307

Note:

Transponder on request.

The new aluminium leg system profile



Dimensions: 60 x 23 mm
 Grooves: 4 T-grooves 17 mm wide
 2 T-grooves 12 mm wide
 Central pipe: to house the base plates etc.

Length of profile	Order No. Profile naturally anodized E6 EV1	Order No. Profile powder-coated white aluminium RAL 9006	Order No. profile powder-coated black-gray RAL 7021	Order No. Profile powder-coated gentian blue RAL 5010
1000mm	04.10.0010	04.10.0110	04.10.0210	04.10.0310
1300mm	04.10.0013	04.10.0113	04.10.0213	04.10.0313
1600mm	04.10.0016	04.10.0116	04.10.0216	04.10.0316
1800mm	04.10.0018	04.10.0118	04.10.0218	04.10.0318
2000mm	04.10.0020	04.10.0120	04.10.0220	04.10.0320
2200mm	04.10.0022	04.10.0122	04.10.0222	04.10.0322

The colours of the new aluminium leg system profile

Naturally anodized E6 EV1

White aluminium RAL 9006

Black-gray RAL 7021

Gentian blue RAL 5010

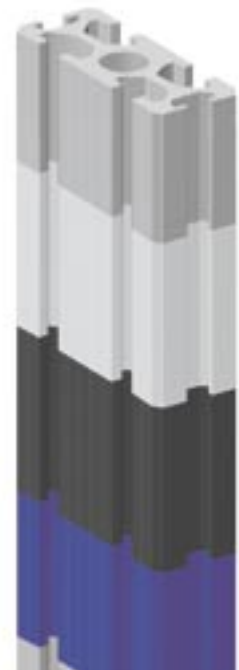

Suitable sliding blocks for the aluminium leg system profile



Order No. 04.10.0001
 Sliding block with M4 thread inclusive spring for a 12 mm groove



Order No. 04.10.0002
 Sliding block with M5 thread inclusive spring for a 12 mm groove



Order No. 04.10.0003
 Swinging-in sliding block with M5 thread for a 17 mm groove with an affixed spring



Order No. 04.10.0004
 Swinging-in sliding block with M6 thread for a 17 mm groove with an affixed spring



Order No. 04.10.0005
 Swinging-in Sliding block with M8 thread for a 17 mm groove with an affixed spring



Order No. 04.10.0006
 Angular sliding block with M6 thread for a 17 mm groove



Order No. 04.10.0007
 Angular sliding block with M6 thread for a 12 mm groove

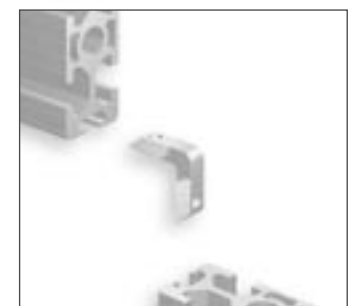
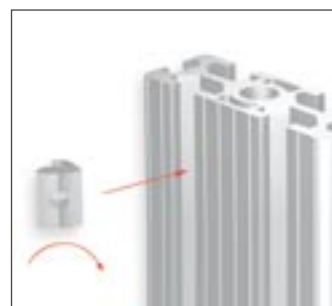

Possible wirings for power and data lines

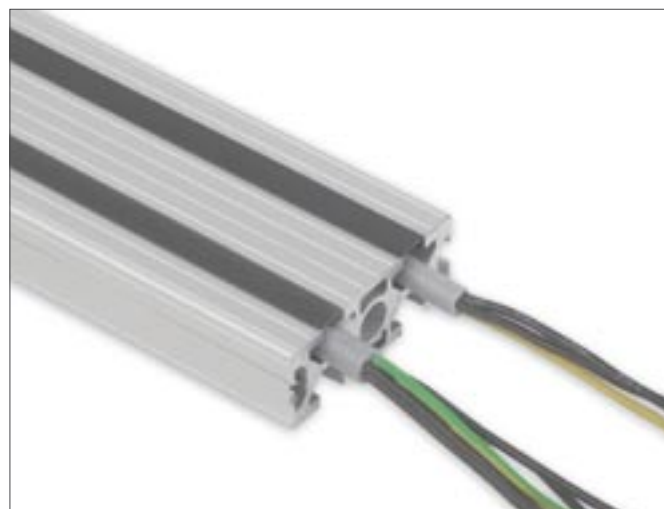

1 = clip profile anthracite for 17 mm grooves (lateral grooves)

2 = clip profile natural aluminium for 12 mm grooves (grooves at the front and at the back)

The modern aluminium leg system profile combines an optimal functionality with a maximum of economy. 6 integrated wiring channels guarantee sufficient space for the data and power lines.

New clip profiles made of plastic and aluminium close the wiring space flexibly and thus ensure an excellent performance and are simultaneously nice to look at.

With a high number of cables additional add-on channels can be adapted simply and flexibly.

The clip profiles cover the space for the cables which are sufficient for 1-phase or 3-phase power supply lines. Data lines can also nicely be placed in the same space as the cable. For covering cable space the clip profiles are simply and flexibly pressed into the grooves.



Also the 12 mm groove at the front can be covered by a suitable clip profile made of aluminium. Therefore, the aluminium leg system profiles can also be used in clean rooms.

The lateral 17 mm grooves are covered with the clip profile made of plastic. If need be, 1 to 4 grooves can be used for the cables. This always guarantees the separation of power and data lines. At the outlet position of the cables, the clip profile is simply interrupted.

Using the clip profile technique even lines with the connector can be placed-in without having to dismount the connector. A considerable advantage of this system!

Clip profile for	Profile length					
	Order No. for 1000mm	Order No. for 1300mm	Order No. for 1600mm	Order No. for 1800mm	Order No. for 2000mm	Order No. for 2200mm
12 mm grooves (at the front, natural aluminium)	04.10.0510	04.10.0513	04.10.0516	04.10.0518	04.10.0520	04.10.0522
17 mm grooves (lateral, anthracite plastic)	04.10.0610	04.10.0613	04.10.0616	04.10.0618	04.10.0620	04.10.0622

The new aluminium leg system profile in function



For straight storage boards

in connection with a system channel installed underneath



For inclinable storage boards

For 19" device cockpits

optionally with 3 or 6 HE, with a system channel installed underneath or with a steel frame



For system components for assembly halls

Extension arms, perforated sheet metal plates, swivel arms etc.

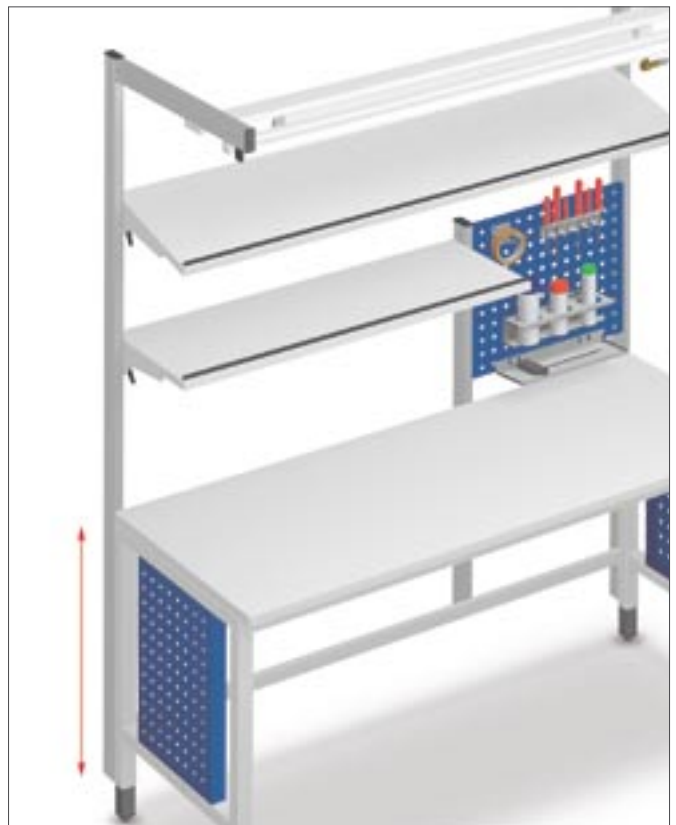

The storage board programme

The new range of storage boards can directly be adapted to the back of the aluminium leg system profile. Due to the grooves in the aluminium leg system profile, all types of storage boards can be steplessly adjusted in height. 3 models are available:

1. Storage board module for a system channel installed underneath

Material: 30 mm thick chipboard with a top of fine chipboard, coated with laminate, not conductive alternatively volume conductive of EGB/ESD design 360 mm deep

Width of table [mm]	not conductive	conductive EGB/ESD
1200	04.11.1230	04.11.1231
1600	04.11.1630	04.11.1631
1800	04.11.1830	04.11.1831
2000	04.11.2030	04.11.2031

Note: The system channel has to be ordered separately, see page 26

2. Storage board module, steplessly inclinable, with a steel frame installed underneath

Material: 30 mm thick chipboard with a top of fine chipboard, coated with laminate, not conductive alternatively volume conductive of EGB/ESD design inclusive a stopper edge at the front 360 mm deep.

Width of table [mm]	not conductive	conductive EGB/ESD
1200	04.11.1232	04.11.1233
1600	04.11.1632	04.11.1633
1800	04.11.1832	04.11.1833
2000	04.11.2032	04.11.2033

3. Storage board module made of sheet steel, steplessly inclinable and adjustable in depth

Material: sheet steel powder-coated inclusive stopper edge at the front 360 mm deep

Width of table [mm]	not conductive	conductive EGB/ESD
1200	04.11.1234	04.11.1235
1600	04.11.1634	04.11.1635
1800	04.11.1834	04.11.1835
2000	04.11.2034	04.11.2035

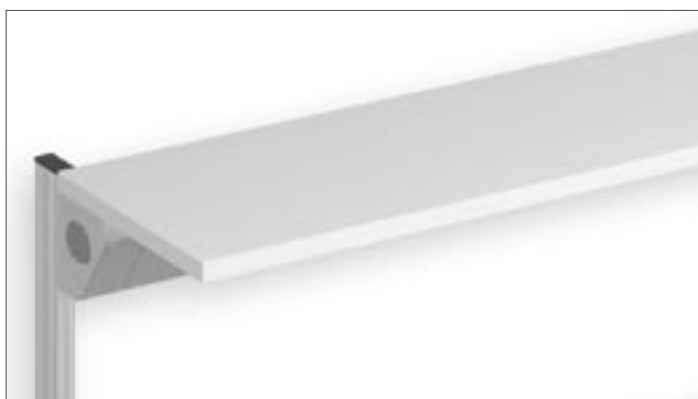

The universal ABZ® system channel, adjustable in height

Since the first presentation on the market in the year 1986 this system component has been continuously further developed and its performance has been considerably improved. This erfi innovation represents today a nearly indispensable component for all communicative and technical fields of work.

The channel can be equipped with the efficient 19 inch insert board programme. Innovative illumination engineering, modules such as fuse protections, sockets, small current supplies, soldering stations, compressed air supplies, various measuring devices etc. can ideally be integrated in this system. The entire system is height adjustable and thus flexibly adaptable to changes.



The system channel as self-supporting and independent element. Form Follows Function. A formula of success which has been optimally integrated in this element.



In connection with storage boards the system channel gets another function. The channel is a solid supporting structure.



Some system channels for general functions can be inserted in a modular table with several levels. The example shows a system channel on the lower level with short field light sockets and soldering stations and on the upper level a system channel with sockets, isolating transformer, data socket etc.



On the back of an adaptable aluminium profile further functions can be attached to the system channel such as accumulator, tool storage, perforated sheet metal plates, rotary table for small articles, device platform etc. Due to the shelf for the soldering iron, the same floats above the table top. The soldering station is installed in the system channel. This creates space and order on the working place.



The shape of the system channel allows also the direct installation on the working place and is, therefore, a useful variant for the energy attachments. The inclined front of the device offers in addition ergonomic advantages for the operator.

Width of table	Width of system channel (TE units)	Order No.
1200mm	1194mm (234 TE)	04.12.1200
1600mm	1594mm (313 TE)	04.12.1600
1800mm	1794mm (352 TE)	04.12.1800
2000mm	1994mm (391 TE)	04.12.2000

The aluminium profile for system channels, adaptable at the back

By means of an aluminium profile which is adaptable at the back additional functional components (order numbers see below) can be fitted to the system channel.

Cross section:

System channel with an aluminium profile, adaptable at the back

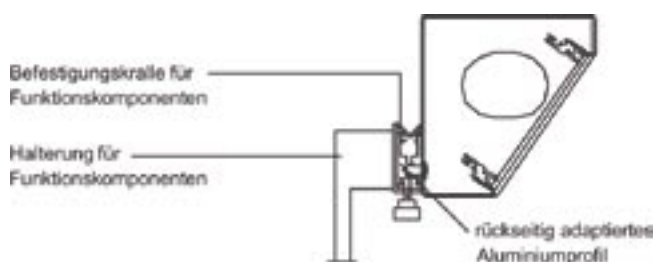

For system channels in ABZ® tables

Width of table	Order No.
1200 mm	04.12 .1202
1600 mm	04.12 .1602
1800 mm	04.12 .1802
2000 mm	04.12 .2002



Functional components

Holder for screwdriver

Width = 65mm

Depth = 170mm

Height = 240mm

Order No. 04.12 .001



Note: indication of height H = bottom edge of functional component to bottom edge of system channel

Tool holder with 5 places

Width = 150mm

Depth = 50mm

Height = 200mm

Order No. 04.12 .002



Tool holder with 19 places

Width = 440mm

Depth = 50mm

Height = 200mm

Order No. 04.12 .003



Tin holder for sprays
Ø 55 mm

Width = 550mm

Depth = 110mm

Height = 210mm

Order No. 04.12 .004



Holder for soldering iron

Width = 65mm

Depth = 220mm

Height = 200mm

Order No. 04.12 .005



Circular storage plate 360°
for small items

Width = 295mm

Depth = 320mm

Height = 200mm

Order No. 04.12 .006



Storage plate

Width = 320mm

Depth = 310mm

Height = 200mm

Order No. 04.12 .007



Perforated sheet metal plate
Accessories for perforated sheet metal plates see page 54

Width = 540mm

Depth = 10mm

Height = 200mm









Order No. 04.12 .008

highlight – the innovative lighting engineering



The erfi lighting engineering sets new standards in function, non-glaring, comfort and design. The light helps decisively to feel well at the working place. With the newly developed system lighting highlight, we managed to realise an absolutely non-glaring light for the working place. An innovative active light grid creates perfect light. The lamp of different designs is inserted in the system channel and

is thus part of the working place. An additional considerable advantage of the highlight lighting technology is the independence of the installation height. Up to 1,40 m height the active light grid guarantees non-dazzle working.

Article	All lamps (without sensolight) are equipped with an On/Off switch.	Power (watt)	TE-units	Order No.	
				fluorescent lamp ballast	electronic
Short lamps single power		36 W	95 TE	AL04.1.361	AL04.1.362
Short lamps double power		55 W	120 TE	AL04.1.551	AL04.1.552
Short lamps double power		2 x 36 W	2 x 95 TE	AL04.2.361	AL04.2.362
Short lamps double power		2 x 55 W	2 x 120 TE	AL04.2.551	AL04.2.552
Long lamps single power		36 W	250 TE	AL04.3.361	AL04.3.362
Long lamps single power		58 W	310 TE	AL04.3.581	AL04.3.582
Long lamps double power		2 x 36 W	250 TE	AL04.4.361	AL04.4.362
Long lamps double power		2 x 58 W	310 TE	AL04.4.581	AL04.4.582

erfi-sensolight® - the new light dimension

erfi-sensolight stands for a new light dimension (registered design No. 202 05 736 4). Sensolight allows a clear improvement regarding ergonomics and energy consumption. erfi-sensolight is available in 3 different designs.



erfi-sensolight® level 1

Contactless switching on / off

The integrated lamp can easily be turned on/off without contact. By simply getting closer to the system channel with the hand, the sensor integrated in the system channel switches on or off. The function is so developed that an unintentional switching on / off is avoided.



erfi-sensolight® level 2

Contactless switching on / off and presence-dependent turning off (control of presence)

The additional sensor for presence guarantees that a short time after leaving the working place the light will be deactivated. The light turns on automatically when coming closer again to the working place. The control of presence also turns off when the on / off sensor will be deactivated.



erfi-sensolight® level 3 Contactless switching on / off and presence-dependent turning off (control of presence) and daylight control system with dimmer function

The daylight control system guarantees a perfect regulation of light at any hour of the night or day.

1. Dimmer function

By means of a dimmer the desired amount of light can be adjusted.

2. Daylight control system

If the ambient light is enhanced for example by sunshine, the lamp power reduces automatically. If the ambient light is reduced for example at dawn/dusk or by clouds, the amount of light is automatically increased. A regular and pleasant amount of light is thus ensured.

Savings: Particularly with level 2 and 3, considerable reductions in power consumption are guaranteed. Suitable for system channels.

erfi-sensolight® level 3 is only possible with the electronic fluorescent lamp ballast.

Article		TE fluorescent	Order No.
erfi-sensolight® level 1	Contactless switching on/off	10 TE	A61.001
erfi-sensolight® level 2	Contactless switching on/off and presence-dependent switching (control of presence)	10 TE	A61.002
erfi-sensolight® level 3	Contactless switching on/off, presence-dependent switching (control of presence) and daylight regulation by dimmer	10 TE	A61.003

Safety and switchgears

Note: Overall height: 113 mm

The insert board programme acto is useable with the following system components:

- System channel
- Energy attachment, energy cockpit
- Swivelling attachment
- 19" combined attachment, 19" combine cockpit

The insert board programme acto® Safety and switchgears (page 30) alternating voltage supplied single-phase and three-phase (page 31-32)

- Socket modules Supply modules
- Non-earthed small alternating voltage
- Non-earthed alternating voltage
- Non-earthed minimum three- phase voltage
- Three-phase modules

Variable alternating voltage supply single-phase (page 33)

- Regulating transformers, non-earthed
- Regulating transformers, earthed

Direct voltage supply (page 34-35)

- Fixed voltage sources
- Regulating power packs, telecontrolable

Function generators (page 36-37)

- Function generators 10 MHz and 20 MHz
- Function generators, telecontrolable

Telecontrol software highlink® (page 37)

Pneumatic units (page 38)

Energy and accessory instruments (page 38-39)

- RC-decades
- R-logades
- Continuity tester
- Soldering station
- Closed circuit network
- Data sockets
- Telephone sockets
- Interfaces
- Empty panels

TE = Teilungseinheit - Division unit

1 TE = 5,08mm



Single-phase
Order No. A52.003

NFI switch:

Motor protection switch:

Phase control lamps:

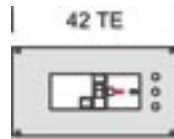

Three-phase
Order No. A53.011

Fault current 30 mA,
nominal current 25 A

10-16 A with under-
voltage circuit breaker

L1 or L1, L2, L3 resp.



Single-phase
Order No. A52.004

Key-operated circuit closer

Emergency shut-off
push-button:

Motor protection
switch:

Phase control lamps:



Three-phase
Order No. A52.005

with potential-free
contact for connection
of an available room
emergency shut-off

10-16 A with undervolt-
age circuit breaker

L1 or L1, L2, L3 resp.



Single-phase
Order No. A53.001

Emergency shut-off
push-button:

NFI switch:

Motor protection
switch:

Phase control lamps:

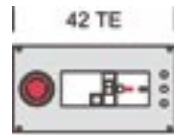

Three-phase
Order No. A53.010

with potentialfree
contact for connec-
tion of a room emer-
gency shut-off

Fault current 30 mA,
nominal current 25 A

10-16 A with under-
voltage circuit breaker

L1 or L1, L2, L3 resp.



Single-phase
Order No. A53.014

Key-operated circuit closer

Emergency shut-off
push-button:

NFI switch:

Motor protection
switch:

Phase control lamps:



Three-phase
Order No. A53.012

with potentialfree con-
tact for connection of a
room emergency shut-off

Fault current 30 mA,
nominal current 25 A

10-16 A with undervolt-
age circuit breaker

L1 or L1, L2, L3 resp.



Single-phase
Order No. A53.008

Key-operated circuit closer

NFI switch:

Motor protection switch:

Phase control lamps:

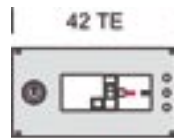

Three-phase
Order No. A53.013

Fault current 30 mA,
nominal current 25 A

10-16 A with un-
dervoltage circuit
breaker

L1 or L1, L2, L3 resp.



Single-phase
Order No. A53.006

Emergency shut-off
push-button:

Motor protection
switch:

Phase control lamps:



Three-phase
Order No. A53.007

with potentialfree
contact for connection
of a room emergency
shut-off

10-16 A with undervolt-
age circuit breaker

L1 or L1, L2, L3 resp.



**Emergency shut-off
push-button:**
with potential-free
contact for connection
to an available room
emergency shut-off

Order No. A51.001



Order No. A51.002
outsmart-safe by
a integrated key-
operated switch



Order No. A51.003
with separate key-
operated circuit closer

Alternating voltage supplies, single-phase

Note: Overall height: 113 mm

Socket modules

- Earthing contact sockets 230 V, 50 Hz, 16 A
- As standard pebble-gray, RAL 7032 (against an extra other colours and models are available)

Without mains switch

|14TE|



Best.-Nr. A11.016

| 28 TE |



Best.-Nr. A12.002

| 42 TE |



Best.-Nr. A13.00*

| 56 TE



Best.-Nr. A14.001

| 70 TE



Best.-Nr. A15.001

| 84 TE



Best.-Nr. A16.001

With mains switch

| 28 TE |



Best.-Nr. A12.01E

| 42 TE |



Best.-Nr. A13.00E

| 56 TE



Best.-Nr. A14.002

| 70 TE



Best.-Nr. A15.002

| 84 TE



Best.-Nr. A16.002

| 98 TE



Best.-Nr. A17.001

Supply modules

|14TE|



Order No. A11.015

PE
1 Safety laboratory socket 4 mm, 230 V, 50 Hz, 16 A

|14TE|



Order No. A11.021

L1, N, PE
3 Safety laboratory sockets 4 mm, 230 V, 50 Hz, 16 A

|14TE|



Order No. A11.024

2 x L1, N, PE
6 Safety laboratory sockets 4 mm, 230 V, 50 Hz, 16 A

|14TE|



Order No. A11.022

CEE socket, 2-pole + PE, 6 h 230 V, 50 Hz, 16 A, with a blue hinged cover

Additional prices

for sockets replaces the standard earthing contact socket (always per piece)



Order No. A1.102

Earthing contact socket
230 V, 50 Hz, 16 A
orange



Order No. A1.103

Earthing contact socket
with spring cover
230 V, 50 Hz, 16 A
pebble-gray, RAL 7032



Order No. A1.105

Earthing contact socket
with spring cover
230 V, 50 Hz, 16 A
orange



Order No. A1.106

Earthing contact socket Switzerland
230 V, 50 Hz, 16 A (SEV 13)
pebble-gray, RAL 7032



Order No. A1.107

Earthing contact socket France
230 V, 50 Hz, 16 A
pebble-gray, RAL 7032



Order No. A1.108

Earthing contact socket Italy
230 V, 50 Hz, 16 A
pebble-gray, RAL 7032



Order No. A1.109

Earthing contact socket Great Britain
240 V, 50 Hz, 13 A
pebble-gray, RAL 7032



Order No. A1.110

Earthing contact socket United States
115 V, 50 Hz, 15 A
pebble-gray, RAL 7032

Alternating voltage supplies, single-phase and three-phase

Note: Overall height: 113 mm

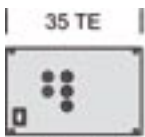

Best.-Nr. A92.01C

Non-earthed minimum alternating voltage

12 V, 24 V/1 A

- 1 illuminated mains switch
- 3 Safety laboratory sockets for supply of non-earthed minimum alternating voltage
- 1 thermal safety switch (primary fuse protection)
- 2 thermal-magnetical safety switches (secondary fuse protection)



Best.-Nr. A92.02C

Non-earthed alternating voltage

230 V/max. 0,5 A 115 VA

- 1 illuminated mains switch
- 1 socket without earthing contact for supply of non-earthed alternating voltage
- 1 safety fuse

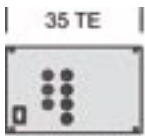

Best.-Nr. A92.01*

Non-earthed minimum alternating voltage

6 V, 8 V, 12 V/1 A

- 1 illuminated mains switch
- 4 Safety laboratory sockets for supply of non-earthed minimum alternating voltage
- 1 thermal safety switch (primary fuse protection)
- 3 thermal-magnetical safety switches (secondary fuse protection)



Best.-Nr. A92.02*

Non-earthed alternating voltage

230 V/max. 0,5 A 115 VA

- 1 illuminated mains switch
- 2 safety laboratory sockets for supply of non-earthed alternating voltage
- 1 safety fuse



Best.-Nr. A93.010

Non-earthed minimum alternating voltage

6 V, 12 V, 18 V, 24 V, 36 V, 42 V/ 3 A

- 1 illuminated mains switch
- 4 Safety laboratory sockets for supply of non-earthed minimum alternating voltage
- 1 thermal safety switch (primary fuse protection)
- 3 thermal-magnetical safety switches (secondary fuse protection)



Best.-Nr. A11.03C

Supply module

2 x 5 safety laboratory sockets
400/230 V, 50 Hz, 16 A



Best.-Nr. A93.011

Non-earthed minimum alternating voltage

2 V, 4 V, 6 V, 8 V, 10 V, 12 V/ 10 A

- 1 illuminated mains switch
- 4 Safety laboratory sockets for supply of non-earthed minimum alternating voltage
- 1 thermal safety switch (primary fuse protection)
- 3 thermal-magnetical safety switches (secondary fuse protection)



Best.-Nr. A12.00*

Three-phase module

1 CEE socket,
3 poles + N + PE, 6 h
400/230 V, 50 Hz, 16 A



Best.-Nr. A12.02C

Three-phase module

- 1 CEE socket, 3 poles + N + PE, 6 h
400/230 V, 50 Hz, 16 A
- 5 safety laboratory sockets
L1, L2, L3, N, PE
400/230 V, 50 Hz, 16 A



Best.-Nr. A94.010

Non-earthed minimum three-phase voltage

Delta 3 x 17,3 V/150 VA,
star 3 x 10 V/5 A

- 1 illuminated mains switch
- 4 Safety laboratory sockets L1, L2, L3, N for supply of non-earthed minimum three-phase voltage
- 1 thermal safety switch (primary fuse protection)
- 3 thermal-magnetical safety switches (secondary fuse protection)



Best.-Nr. A12.02*

Three-phase module 1 illuminated mains switch

- 1 illuminated mains switch
- 3 thermal-magnetical safety switches
- 5 safety laboratory sockets
L1, L2, L3, N, PE
400/230 V, 50 Hz, 15 A

Regulating transformers, single-phase

Note: Overall height: 113

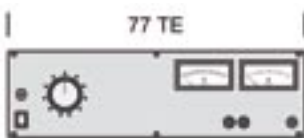

Best.-Nr. A95.010

Regulating transformer (unearthed)
0-30 VAC max. 2 A unearthed,
steplessly adjustable, unstabilized

Output AC:	2 safety laboratory sockets 4 mm
Display:	Moving iron instrument class 2,5, voltage: 0-30 V Moving iron instrument class 2,5, current: 0-2 A



Best.-Nr. A95.011

Regulating transformer (unearthed)
0-30 VAC max. 2 A unearthed,
steplessly adjustable, unstabilized,
changeable to: 0-24 VDC, residual ripple
approx. 50 % by an integrated bridge
connected rectifier

Output AC/DC:	2 safety laboratory sockets 4 mm
Display:	Moving iron instrument class 2,5, voltage: 0-30 V Moving iron instrument class 2,5, current: 0-2 A

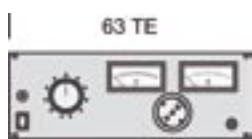

Best.-Nr. A94.030

Regulating transformer (earthed)
0-260 VAC max. 1 A earthed,
steplessly adjustable, unstabilized

Output AC:	Shockproof socket
Display:	Moving iron instrument class 2,5, voltage: 0-260 V Moving iron instrument class 2,5, current: 0-1 A

Note: not useable in system channels



Best.-Nr. A95.012

Regulating transformer (unearthed)
0-24 VAC max. 4 A unearthed,
steplessly adjustable, unstabilized,
changeable to: 0-19 VDC, residual ripple
approx. 50 % by an integrated bridge
connected rectifier

Output AC/DC:	2 safety laboratory sockets 4 mm
Display:	Moving iron instrument class 2,5, voltage: 0-30 V Moving iron instrument class 2,5, current: 0-4 A



Best.-Nr. A92.03C

Regulating transformer (earthed)
0-260 VAC max. 1 A earthed,
steplessly adjustable, unstabilized

Output AC:	3 safety laboratory sockets 4 mm (L1, N and PE)
------------	---

Note: not useable in system channels



Best.-Nr. A93.03C

Regulating transformer (unearthed)
AC: 2-260 VAC max. 1 A unearthed,
steplessly adjustable, unstabilized
DC: 2-200 V DC unscreened, residual ripple
approx. 50 % by an integrated bridge
connected rectifier

Output AC:	3 safety laboratory sockets 4 mm (L1, N and PE)
Output DC:	2 safety laboratory sockets 4 mm

Note: not useable in system channels



Best.-Nr. A94.031

Regulating transformer (unearthed)
2 - 260 V AC max. 1 A unearthed,
steplessly adjustable, unstabilized

Output AC:	3 safety laboratory sockets 4 mm (L1, N and PE)
Display:	Moving iron instrument class 2,5, voltage: 0-260 V Moving iron instrument class 2,5, current: 0-1 A

Note: not useable in system channels



Best.-Nr. A94.033

Regulating transformer (unearthed/earthed)
steplessly adjustable voltages,
unstabilized AC: 10-12 V AC max. 12 A
unearthed AC 2: 0 - 24 V AC max. 6 A
unearthed AC 3: 2 - 260 V AC max. 2 A

Output AC 1+2:	2 safety laboratory sockets 4 mm each
Output AC 3:	3 safety laboratory sockets 4 mm (L1, N and PE)
Bridge connected rectifier:	built-in for external wiring

Note: not useable in system channels and energy attachments/cockpits of 130 mm depth



Best.-Nr. A94.032

Regulating transformer (unearthed)
2 - 260 V AC max. 2 A unearthed,
steplessly adjustable, unstabilized,
changeable to: 2-200 V DC by an
integrated bridge connected rectifier

Output AC:	Socket without earthing contact
Output DC:	2 safety laboratory sockets 4 mm
Display:	Moving iron instrument class 2,5, voltage: 0-260 V Moving iron instrument class 2,5, current: 0-2 A

Note: not useable in system channels and energy attachments/cockpits of 130 mm depth system



Best.-Nr. A94.034

Regulating transformer (unearthed/earthed)
steplessly adjustable voltages, unstabilized
AC 1: 0 - 6 V AC max. 15 A unearthed
AC 2: 0 - 18 V AC max. 6 A unearthed,
AC 3: 0 - 42 V AC max. 3 A earthed
AC 4: 2 - 260 V AC max. 2 A earthed

Output AC 1-3:	2 safety laboratory sockets 4 mm each
Output AC 4:	3 safety laboratory sockets 4 mm (L1, N and PE)
Bridge connected rectifier:	built-in for external wiring

Note: not useable in system channels and energy attachments/cockpits of 130 mm depth

Note: All regulating transformers are equipped with 1 thermal (primary) and thermal-magnetical (secondary) over-current releases and 1 illuminated power switch.

Direct-current supplies / Solid voltage sources

Note: Overall height: 113 mm

*Technical Data lengthwise regulated supply units:

Output data	Voltage	5 V	5 V	12 V	12 V	15 V	15 V
	Current	1 A	3 A	1 A	2 A	1 A	2 A
Deviation	Change of voltage load 0-100 %	20 mV	20 mV	50 mV	80 mV	50 mV	80 mV
Residual ripple	Voltage with nominal load	0,5 mVeff					
Settling time	Load bounce from 0 % to 100 %	15 µs					

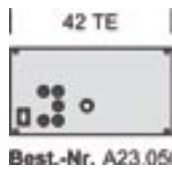

Tracking supply unit

3 to +/- 15 V/1 A and 5 V/1 A
lengthwise regulated supply unit*

Best.-Nr. A23.05C

Output data:	permanently resistant to sustained short circuit, lengthwise regulated, switchable in series and parallel
Outputs:	4 mm safety laboratory sockets



Solid voltage source

5 V/3 A
lengthwise regulated supply unit*

Best.-Nr. A22.05C

Output data:	resistant to sustained short circuit, lengthwise regulated, switchable in series and parallel
Outputs:	4 mm safety laboratory sockets



Solid voltage source

±5 V/3 A
lengthwise regulated supply unit*

Best.-Nr. A24.050

Output data:	permanently resistant to sustained short circuit, lengthwise regulated, switchable in series and parallel
Outputs:	4 mm safety laboratory sockets



Solid voltage source

24 V/1,5 A
clock-actuated supply unit

Technical data clock-actuated supply unit:

Output specification:
Deviations
- Input voltage change: +/- 0,2% max.
- Change of load: +/- 0,8 % max.
General specification:
Temperature coefficient: +/- 0,01 % /C°

Output data:	permanently resistant to sustained short circuit, switchable in series and parallel
Outputs:	4 mm safety laboratory sockets



Solid voltage source

24 V/5 A (10 A peak)
clock-actuated supply unit

Technical data clock-actuated supply unit:

- Double nominal peak power when switching-on
- Power factor and harmonic wave improvement as per EN61000-3-2
- Load stabilization: 192 mV max.
- Residual ripple and noise: 360 mV max.

Output data:	permanently resistant to sustained short circuit, switchable in series and parallel
Outputs:	4 mm safety laboratory sockets

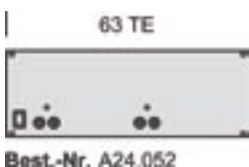

Solid voltage source

2 x 12 V/2 A
switchable parallel and in series resp. lengthwise regulated supply unit*

Best.-Nr. A24.052

Output data:	permanently resistant to sustained short circuit, switchable in series and parallel
Outputs:	4 mm safety laboratory sockets

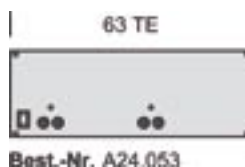

Solid voltage source

2 x 15 V/2 A
switchable parallel and in series resp. lengthwise regulated supply unit*

Best.-Nr. A24.053

Output data:	permanently resistant to sustained short circuit, lengthwise regulated, switchable in series and parallel
Outputs:	4 mm safety laboratory sockets



Solid voltage source

±/- 12 V/1 A and 5 V/3 A
lengthwise regulated supply unit*

Best.-Nr. A25.050

Output data:	permanently resistant to sustained short circuit, switchable in series and parallel
Outputs:	4 mm safety laboratory sockets 1 shockproof socket 230 V / 16 A in addition

Note: not useable in system channels



Solid voltage source

±15 V/1 A and 5 V/3 A
lengthwise regulated supply unit*

Best.-Nr. A25.051

Output data:	permanently resistant to sustained short circuit, lengthwise regulated, switchable in series and parallel
Outputs:	4 mm safety laboratory sockets 1 shockproof socket 230 V/16 A in addition

Note: not useable in system channels

Telecontrollable regulating supply units

with integrated interface at the front, ramp generator and device software highlink® and LabVIEW device drivers resp. (see page 37, to be ordered separately) Note: Overall height: 113 mm

Technical Data:

Interface: addressable serial interface RS-232
 Ramp generator: for any voltage curves
 Ramp parameters: initial and final voltage, speed, time per ramp step, number of cycles
 Operation: manual or remote controlled
 Bidirectional function: output voltage and current limitation programmable, actual measured value transfer of current and voltage via interface
 Plug and Play: automatic recognition of device type by highlink® software or LabVIEW device driver (option)
 Output data: permanently resistant to sustained short circuit, lengthwise regulated, switchable in series and parallel

Deviation in case of load changes of 0 to 100 %
 Voltage: 2 mV/A
 Current: 0,02 mA/V
 Temperature coefficient:
 Voltage: 0,005 %/K
 Current: 0,013 %/K
 Residual ripple:
 Voltage: 0,2mV_{eff}
 Current: 0,5mA_{eff}
 Stabilization time in case of a load bounce of
 0 % to 100 %: 15 µs
 100 % to 0 %: 500 µs
 Outputs: 4 mm safety laboratory sockets



Analoganzeige



Digitalanzeige

Single regulation supply unit
 - 1 common analog or digital display resp. for voltage and current
 - with double scale, reversible
 - OUTPUT-OFF function

Voltage	Current	Display V/A reversible	Order No.
0-15 V	0-2 A	analog	A23.Fo10
		digital	A23.Fo11
0-30 V	0-1 A	analog	A23.Fo12
		digital	A23.Fo13
0-30 V	0-2 A	analog	A23.Fo14
		digital	A23.Fo15



Analoganzeigen



Digitalanzeigen

Single regulation supply unit
 - 1 analog or digital display resp. each for voltage and current
 - with double scale, reversible
 - OUTPUT-OFF function

Voltage	Current	Display V/A reversible	Order No.
0-15 V	0-2 A	analog	A23.Fo20
		digital	A23.Fo21
0-30 V	0-1 A	analog	A23.Fo22
		digital	A23.Fo23
0-30 V	0-2 A	analog	A23.Fo24
		digital	A23.Fo25



Analoganzeigen



Digitalanzeigen

Multiple regulation supply unit
 - per channel 1 common analog or digital display resp. for voltage and current
 - with double scale, reversible
 - OUTPUT-OFF function

Voltage	Current	Display V/A reversible	Order No.
2 x 0-15 V	2 x 0-2 A	analog	A27.Fo10
		digital	A27.Fo11
2 x 0-30 V	2 x 0-1 A	analog	A27.Fo12
		digital	A27.Fo13
2 x 0-30 V	2 x 0-2 A	analog	A27.Fo14
		digital	A27.Fo15



Analoganzeigen



Digitalanzeigen

Multiple regulation supply unit
 - per channel 1 common analog or digital display resp. for voltage and current
 - OUTPUT-OFF function

Voltage	Current	Display V/A reversible	Order No.
2 x 0-15 V	2 x 0-2 A	analog	A27.Fo20
		digital	A27.Fo21
2 x 0-30 V	2 x 0-1 A	analog	A27.Fo22
		digital	A27.Fo23
2 x 0-30 V	2 x 0-2 A	analog	A27.Fo24
		digital	A27.Fo25

Telecontrollable functional generators inclusive counters

Note: Overall height: 113 mm

erfi is the first manufacturer of laboratory furniture systems for electric engineering and electronics who presents telecontrollable 19" functional generators and 19" regulating supply units in connection with a modern network software (highlink) in professional working place systems. Another proof of the innovative leadership of erfi. The completely newly developed functional generator family offers an excellent functionality and parameters such as remote

control by means of a modern software, large frequency range up to 20 MHz, amplitudes up to 30 V_{ss} and frequency counters of up to 100 MHz. This new generator generation meets all requirements one can think of. Multi-lingual menu technique in connection with elegant rotary encoders and the new „Comand“ function keys are a special feature of this generator class. New portalecasing render the device programme acto even independent of the relevant working place.

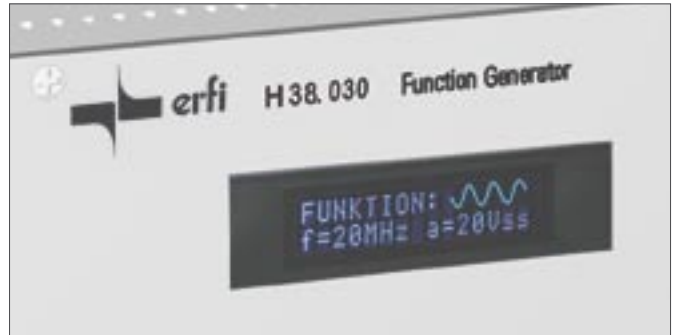

The new graphic display of vacuum fluorescent technique allows perfect reading even at a distance of 3 m, independently of the reading angle! The display is in blue and has a high focus and brilliance.

Order No.	Size	Design
A34.020	56TE	0,1Hz – 20MHz, 20V _{ss} , Counter up to 30 MHz
A34.021	56TE	0,1Hz – 10MHz, 30V _{ss} , Counter up to 30 MHz
A34.022	56TE	0,1Hz – 20MHz, 20V _{ss} , Counter up to 30 MHz
A34.023	56TE	0,1Hz – 10MHz, 30V _{ss} , Counter up to 30 MHz
A34.050	-	Amplifier approx. 20dB, DC

- telecontrollable by RS232 or USB2.0 interface (options)
- comprehensive control software highlink (option) or LabVIEW device driver (option)
- innovative menu-driven commutation with modern graphic display in blue colour
- Comand function keys for a fast access to main functions
- elegant rotary encoder for a comfortable menu control
- excellent frequency range up to 20 MHz
- 8-digit frequency counter up to 100 MHz

Display: graphic display of vacuum fluorescent technique, blue

Menu language: reversible German / English

Operation concept: elegant rotary encoder with push function as well as Comand function keys for optimal handling

Functions: sinus, delta, rectangle, saw tooth, ramp operation, amplifier, DC, individual impulse, variable pulse-duty factor

Operation modes: unsolicited, external wobbling, internal wobbling (sweep operation), PWM operation

Frequency range: 0,1 Hz-20 MHz or models A34.020 and A34.022
0,1 Hz-10 MHz for models A34.021 and A34.023

Amplitude: 0-20 V_{ss} for models A34.020 and A34.022
0-30 V_{ss} for models A34.021 and A34.023

Amplifier: approx. 20dB amplification, DC, order No. A34.050

Individual impulse: variable, positive impulse with release by a key, adjustable impulse length

Outputs: 20V_{ss} no-load operation for models A34.020 and A34.022
30V_{ss} no-load operation for models A34.021 and A34.023

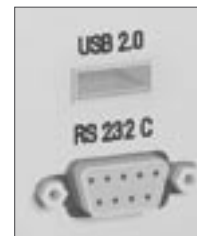

USB Port 2.0 interface (at the front, option)

RS232 serial interface (at the front, option)

Inputs: 5V TTL-compatible, 50Ω-output impedance
Ext, Ub, m OWM PWM In, VCO In, reductor: 0-30 dB continuous, in addition 20dB and 40dB connectable through the same socket

DC offset: -10 to +10V, 0V with push-button

Wobble operation, external:
VCO input: 0-5 V control voltage input for frequency change of max. 1:100

Wobble operation, internal: Sweep operation, start and stop frequency, wobble frequency: max. 100 Hz in 1Hz steps

PWM operation:
Control input: -2,5 V to +2,5 V control voltage input for pulse-pause ratio

Frequency counter:
Measuring range: 0,1 Hz to 30 MHz for models A34.020 and A34.021
0,1 Hz to 100 MHz for models A34.022 and A34.023
Input: external, BNC socket
Input voltage: 0,5V_{eff} to 100V_{eff}
Display: 2 x 16 Digits

Telecontrol operation for functional generators and counter operation (option)

Due to the interfaces available as an optionally (serial RS232 or USB2.o) the new functional generators are useful for everything. The telecontrol allows the programming of the functional generators and of the integrated counter. This functionality makes it possible to use the new functional generator family for automated measuring and regulating. The telecontrollable functional generators have been developed for the industrial use as well as for the didactic training centre. They are an ideal and in our times modern tool with many valuable functions.

Interfaces: (option)

Order No.	Design
A34.020.01	serial interface RS232 (option), alternatively:
A34.020.02	USB2.o interface (option)

Note:

When ordering the interface A34.020.01 or A34.020.02, please order also the highlink® software A34.020.10 or the LabVIEW device driver A34.020.11.

The software „highlink“ or the „LabVIEW device driver“, both available as an option, allow the comfortable access to the device.

The following parameters are programmable with limits by means of the optional interfaces (RS232 or USB2.o):

- Selection of the operation mode:
 - unsolicited, external wobbling, internal wobbling (sweep operation), PWM operation
- Functions/curves:
 - sinus, delta, rectangle, saw tooth, ramp operation, amplifier, DC, individual impulse, variable pulse-duty factor
- Frequency:
 - 0-20 MHz or 0-10 MHz resp.
- Amplitude:
 - 0-20V_{ss} or 0-30V_{ss} resp.
- DC-Offset:
 - 10V to +10V
- Reductor:
 - 0-30dB, 20dB and 40dB
- Sweep parameter:
 - start and stop frequency, wobble frequency
- Counting frequency:
 - can be read

highlink® - software and LabVIEW device driver (option)

Order No.	Design
A34.020.10	highlink® - software for functional generators and for regulating supply units

highlink® – software:

This innovative software package allows the programming of telecontrollable parameters of the erfi functional generators (see above) as well as the parameters of the telecontrollable erfi regulating supply units (see page 35) due to the user-friendly operating panel. Virtual transformers and input spaces ensure an optimal and rational handling for telecontrol operation. highlink® is a registered trademark and allows in addition the data logging of the generators and supply units. Programmable ramps by means of supply units are also possible through table functions. (See page 35 and the separate catalogue „Telecontrollable supply unit generation highlab and basic). Consequently, highlink® is the decisive step to link groups of devices and working places. Complete laboratories and individual devices can be telecontrolled in a modern way. highlights such as the plug-and-play function ensure that each connected and active device is automatically recognized. A comfort unattainable in the past, joined with perfect functionality.



LabVIEW device drivers

The erfi device drivers are ideally suited for all developers using the development tool LabVIEW. The individual functions of the erfi functional generators and erfi supply units (see page 35) are summarized in libraries and can easily be incorporated in the project concerned.

Order No.	Design:
A34.020.11	LabVIEW device driver for erfi functional generators
A34.020.12	LabVIEW for erfi regulating supply units (see page 35)

Pneumatic units / energy and accessory devices

Note: Overall height: 113 mm



Pneumatic supply

- Output pressure for coupling 1 and 2: 0 to 3 bar and 0 to 10 bar resp., continuously adjustable, pressure reducer with fixing device and excess pressure protection
- Output pressure for coupling 3: direct taking-out of the input pressure
- Output: All 3 coupler sockets KD 1/8 with automatic shut-off
- Input: at the back for a hose of 6 mm inside diameter



Compressed air outlet

Compressed air inlet:
at the back for a hose of 6 mm inside diameter
Compressed air outlet:
air-operated coupling with automatic shut-off
DN5 Operating pressure: max. 10 bar

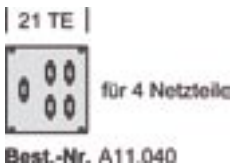

Bus coupler field

Allows the drive of several supply unit and functional generators by a PC. In connection with the device driver highlink, all connected devices can be safely controlled by a PC. (A condition hereof: highlink® software)

- 1 serial connection at the front for PC (RS232 adressable)
- 4 or 8 pcs. resp. serial connections at the front for 4 or 8 telecontrollable erfi devices, completely interlinked at the back.

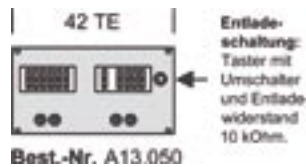

RC-decade

Combination device with integrated R and C decade for the experimental finding-out of resistance and capacity values.

Discharge switching:	Resistance range: 1 Ohm to 999,999 kOhm in steps of 1 Ohm
Precision:	= ± 1% above 40 Ohm = ± 4% from 40 Ohm to 13 Ohm = ± 6 % from 12 Ohm to 3 Ohm = ± 10 % with 2 Ohm and 1 Ohm
Current-carrying capacity:	max. 1W
Voltage:	max. 250 V (50 Hz)
Capacity range:	100 pF to 9.9999 µF in steps of 100 pF
Precision:	= ± 2 % above 1nF = ± 10 % from 1 nF to 100 pF

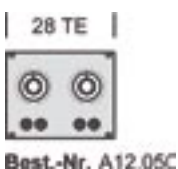

RC Logade

Resistance range:	100 Ohm to 680 kOhm series E 6
Tolerance:	± 2 %
Current-carrying capacity:	max. 0,5 W
Voltage:	max. 400 V DC
Capacity range:	100 pF to 680 nF series E 6
Tolerance:	± 10 %
Voltage:	max. 250 V DC



L-Logade

For the experimental finding-out of inductivity values with testing and experimenting circuits. The inductivity can be adjusted by a rotary-type switch.

Range of values:	1 µH to 4700 µH, graded as per series E 6 (23 values)
Precision:	1 µH to 33 µH +- 10 % 47 µH to 4800 µH +- 5 %
Operating voltage:	max. 1000 V DC
Operating current:	max. 63 mA, with a fine fuse protection

Energy and accessory devices / others / empty panels

Note: Overall height: 113 mm

28 TE



Best-Nr. A12.06C

Continuity tester, optical and acoustical
optical by a green luminous field for resistances of low impedance, acoustical by a loudspeaker for resistances of high impedance

Connection: 2 pcs. 4 mm safety laboratory sockets for optical testing, 2 pcs. 4 mm safety laboratory sockets for acoustical testing

Electric strength: up to approx. 400 V AC with acoustical continuity testing

Testing voltage: aprox. 24 V AC with optical continuity testing

42 TE



Best-Nr. A13.06C

Solder station 80 Watt with digital indication
Scope of supply inclusive solder pencil WSP 80 and holder WPH for WSP 80

- electronic regulating electronics
- temperature range 50° C to 450° C, adjustable by keys
- 3-digit digital indication for nominal and set value
- tolerance $\pm 2\%$ of the final value
- automatic tool recognition
- external input device (WCB1/WCB2, optional) can be connected for time and locking positions.
- equipotential bonding (in initial state tightly earthed)

14 TE



Best-Nr. A11.01*

Ring circuit panel
6 pcs. 4 mm safety laboratory sockets with 6,3 mm flat plug for connection of ring circuits, not wired

21 TE



Best-Nr. A11.06C

Ring circuit panel
- 6 pcs. 4 mm safety laboratory sockets, flat plug for connection of ring circuits, not wired
- 3 pcs. BNC sockets, not wired

28 TE



Best-Nr. A12.01C

Data socket
1 Data socket RJ45, double socket Cat 6, not wired

28 TE



Best-Nr. A12.03C

Telephone socket
1 telephone socket TAE 6 N, triple, not wired

Interface panels

7 TE



Best-Nr. A10.00*

2 pcs. PS2 sockets for keyboard and mouse, inclusive connection cable

7 TE



Best-Nr. A10.00Z

2 pcs. USB sockets, inclusive connection cable

7 TE



Best-Nr. A10.00Z

2 pcs. SubD sockets, 9 poles, male, inclusive connection cable

7 TE



Best-Nr. A10.004

1 pc. SubD socket, 25 poles, female, inclusive connection cable

7 TE



Best-Nr. A10.00E

2 pcs. stereo jack bushes 3,5 mm inclusive connection cable

Empty panels

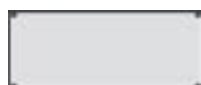

Width	Order No.
14 TE	A01.010
28 TE	A02.010
42 TE	A03.010
56 TE	A04.010
70 TE	A05.010
84 TE	A06.010

Energy attachments and energy cockpits, compact and modular

The energy attachments and energy cockpits are the most economic solution for the basic equipment of an electronic working place. With this attachment and cockpit technology, a lot of measurements can be realised.

In the front they all have a 19 inch rail to take up the 19 inch insert board programme



Energy attachment 130 mm deep, 153 mm high

Width of table (mm)	Equipment capacity	Order No.
1200	228	04.13.1201
1600	307	04.13.1601
1800	346	04.13.1801
2000	386	04.13.2001



Energy attachment 320 mm deep, 153 mm high

Width of table (mm)	Equipment capacity	Order No.
1200	228	04.13.1202
1600	307	04.13.1602
1800	346	04.13.1802
2000	386	04.13.2002

Energy attachments and energy cockpits, compact and modular

The energy cockpits are directly adapted to the rear aluminium leg system and are steplessly adjustable in height.

They are either available as independent unit or combined with a system channel which is installed underneath.



Energy cockpits 130 mm deep, 153 mm high

Width of table (mm)	Equipment capacity	Order No.
1200	228	04.13.1203
1600	307	04.13.1603
1800	346	04.13.1803
2000	386	04.13.2003



Energy cockpits 320 mm deep, 153 mm high

Width of table (mm)	Equipment capacity	Order No.
1200	228	04.13.1204
1600	307	04.13.1604
1800	346	04.13.1804
2000	386	04.13.2004

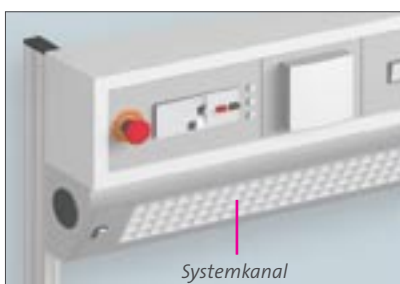

Energy cockpits can also be directly mounted on system channels.

Absolutely flexible, the 19“ device attachments

The 19“ device attachments are available of overall heights of 3HE and 6HE and are suited for the professional integration of the 19“ devices basic and highlab resp.

As a standard the attachments are equipped with a professional 19“ installation mechanism and thus guarantee also the possibility of properly installing 19“ devices of another make.



**19“ / 3 HE device attachment,
straight front**

Attachment depth: 360 mm
Attachment height: 183mm
Attachment width: as per width of table

Width of table (mm)	Equipment capacity	Order No.
1200	224TE/3HE	04.14.1201
1600	303TE/3HE	04.14.1601
1800	342TE/3HE	04.14.1801
2000	382TE/3HE	04.14.2001



**19“ / 3 HE device attachment,
10° inclination of front**

Attachment depth: 360mm
Attachment height: 227mm
Attachment width: as per width of table

Width of table (mm)	Equipment capacity	Order No.
1200	224TE/3HE	04.14.1202
1600	303TE/3HE	04.14.1602
1800	342TE/3HE	04.14.1802
2000	382TE/3HE	04.14.2002



**19“ / 6 HE device attachment,
straight front**

Attachment depth: 360mm
Attachment height: 316mm
Attachment width: as per width of table

Width of table (mm)	Equipment capacity	Order No.
1200	224TE/6HE	04.14.1203
1600	303TE/6HE	04.14.1603
1800	342TE/6HE	04.14.1803
2000	382TE/6HE	04.14.2003



**19“ / 6 HE device attachment,
10° inclination of front**

Attachment depth: 360mm
Attachment height: 360mm
Attachment width: as per width of table

Width of table (mm)	Equipment capacity	Order No.
1200	224TE/6HE	04.14.1204
1600	303TE/6HE	04.14.1604
1800	342TE/6HE	04.14.1804
2000	382TE/6HE	04.14.2004

The DINA 4 – cockpits – functional and versatile

The DINA 4 attachments and DINA 4 cockpits have an inside height of 330 mm and are therefore ideally suited for holding A4 files. Between a 19" /6 HE device cockpit and a DINA 4 cockpit there is a

difference in height of 54 mm. With linear table combinations the 19" device cockpit and the DINA 4 cockpit are flush at the top.



DINA 4 – attachment

The partition wall in the middle allows a high load on the top.

Width of table (mm)	Order No.
1200	04.15.1201
1600	04.15.1601
1800	04.15.1801
2000	04.15.2001

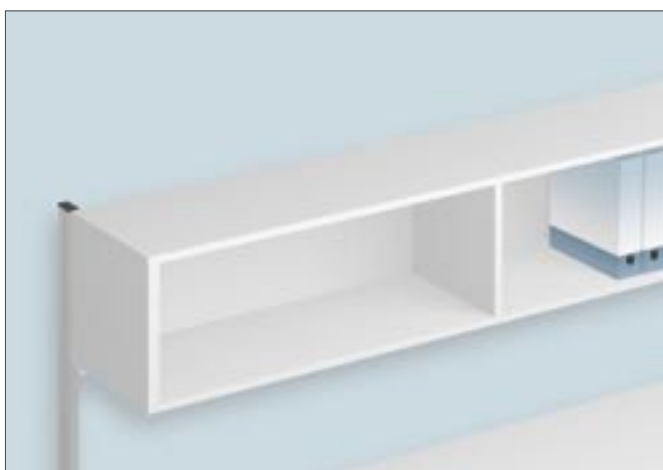

DINA 4 – cockpit with a steel frame fitted underneath

Due to the third level additional working space is created. The cockpit rests on a solid and welded steel frame and allows high loads. By connecting the cockpit to the back of the aluminium leg system profile, it is steplessly adjustable in height.

Width of table (mm)	Order No.
1200	04.15.1202
1600	04.15.1602
1800	04.15.1802
2000	04.15.2002

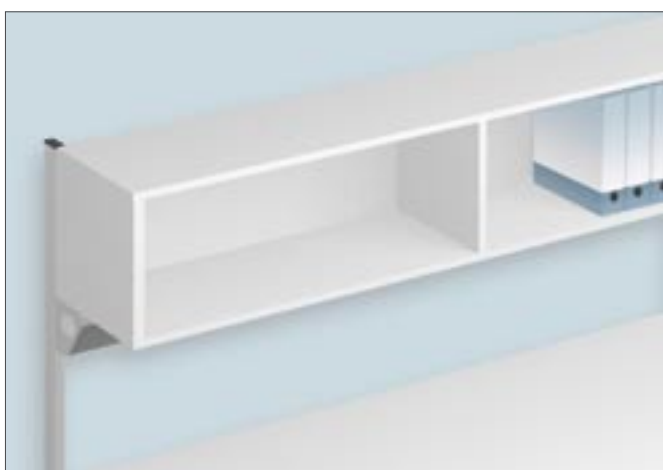

DINA 4 – cockpit for a system channel fitted underneath

This type of cockpit allows the combination with the insert board programme acto. The system channel serves as highly solid support of the cockpit as well as for the installation of the insert board programme acto. Lamps, sockets, data sockets, safety and switching units etc. can be selected. (System channels see page 26-29, insert board programme acto see page 30-39).

Width of table (mm)	Order No.
1200	04.15.1203
1600	04.15.1603
1800	04.15.1803
2000	04.15.2003

Modern and ergonomic, the 19“/3 HE device cockpits

A professional work organisation is a prerequisite everywhere. With the newly developed cockpit modules ABZ offers a great variety. The freely suspended device cockpit was already presented and launched on the market by erfi as forerunner in the electronic industry.

The result of the consistent further development of these ergonomic system components are the overall height and the desing of the front. The device cockpits are mounted to the rear aluminium system profiles.



**19“ / 3 HE device cockpit,
straight front, with a steel frame fitted underneath**

Depth of cockpit: 360mm
 Height of cockpit: 183mm
 Width of cockpit: as per width of table
 Top edge of cockpit: 1600mm

Width of table (mm)	Equipment capacity	Order No.
1200	224TE/3HE	04.16.1201
1600	303TE/3HE	04.16.1601
1800	342TE/3HE	04.16.1801
2000	382TE/3HE	04.16.2001



**19“ / 3 HE device cockpit,
straight front, suitable for a steel frame fitted underneath**

Depth of cockpit: 360mm
 Height of cockpit: 183mm
 Width of cockpit: as per width of table
 Top edge of cockpit: 1600mm

Width of table (mm)	Equipment capacity	Order No.
1200	224TE/3HE	04.16.1202
1600	303TE/3HE	04.16.1602
1800	342TE/3HE	04.16.1802
2000	382TE/3HE	04.16.2002



**19“ / 3 HE device cockpit,
front inclined by 10°, with a steel frame fitted underneath**

Depth of cockpit: 360mm
 Height of cockpit: 227mm
 Width of cockpit: as per width of table
 Top edge of cockpit: 1600mm

Width of table (mm)	Equipment capacity	Order No.
1200	224TE/3HE	04.16.1203
1600	303TE/3HE	04.16.1603
1800	342TE/3HE	04.16.1803
2000	382TE/3HE	04.16.2003



**19“ / 3 HE device cockpit,
front inclined by 10°, suitable for a steel frame fitted underneath**

Depth of cockpit: 360mm
 Height of cockpit: 227mm
 Width of cockpit: as per width of table
 Top edge of cockpit: 1600mm

Width of table (mm)	Equipment capacity	Order No.
1200	224TE/3HE	04.16.1204
1600	303TE/3HE	04.16.1604
1800	342TE/3HE	04.16.1804
2000	382TE/3HE	04.16.2004

Modern and ergonomic, the 19"/6 HE device cockpits

The 19"/6 HE device cockpits offer sufficient space for high-performance and voluminous devices. Big 19" devices of the series high-lab, basic and CANclass as well as all 19" standardized other makes can be elegantly integrated:

- AC regulating and isolating transformers

- high-current supply units
- high-voltage testers
- isolation testers
- protective conductor testers
- leakage current testers etc.



**19" / 6 HE device cockpit,
straight front, with a steel frame fitted underneath**

Depth of cockpit: 316mm
 Height of cockpit: 316mm
 Width of cockpit: as per width of table
 Top edge of cockpit: 1600mm

Width of table (mm)	Equipment capacity	Order No.
1200	224TE/6HE	04.17.1201
1600	303TE/6HE	04.17.1601
1800	342TE/6HE	04.17.1801
2000	382TE/6HE	04.17.2001



**19" / 6 HE device cockpit,
straight front, suitable for a steel frame fitted underneath**

Depth of cockpit: 316mm
 Height of cockpit: 316mm
 Width of cockpit: as per width of table
 Top edge of cockpit: 1600mm

Width of table (mm)	Equipment capacity	Order No.
1200	224TE/6HE	04.17.1202
1600	303TE/6HE	04.17.1602
1800	342TE/6HE	04.17.1802
2000	382TE/6HE	04.17.2002



**19" / 6 HE device cockpit,
front inclined by 10°, with a steel frame fitted underneath**

Depth of cockpit: 360mm
 Height of cockpit: 360mm
 Width of cockpit: as per width of table
 Top edge of cockpit: 1600mm

Width of table (mm)	Equipment capacity	Order No.
1200	224TE/6HE	04.17.1203
1600	303TE/6HE	04.17.1603
1800	342TE/6HE	04.17.1803
2000	382TE/6HE	04.17.2003



**19" / 6 HE device cockpit,
front inclined by 10°, suitable for a steel frame fitted underneath**

Depth of cockpit: 360mm
 Height of cockpit: 360mm
 Width of cockpit: as per width of table
 Top edge of cockpit: 1600mm

Width of table (mm)	Equipment capacity	Order No.
1200	224TE/6HE	04.17.1204
1600	303TE/6HE	04.17.1604
1800	342TE/6HE	04.17.1804
2000	382TE/6HE	04.17.2004

ABZ® - liftline – variable working heights due to the professional clamp connection, alternatively by a crank adjustment or an electric drive resp.



A study has proven that almost 70 % of staff members who had a working place with an integrated height adjustment for a period of three months said that their

well-being improved considerably during this time or that health problems were reduced. And almost all participants namely 92 % realized that the change

between a sitting and a standing position was of advantage.



Technical Data of manual height adjustment

Stroke: 100 mm from 780 mm up to 880 mm
or
200 mm from 780 mm to 980 mm
or
300 mm from 780 mm up to 1080 mm
or
400 mm from 780 mm up to 1180 mm
Adjustment: By unscrewing the clamping screws at all 4 table legs. Interior second pipe in the leg can be extended steplessly.

(*) Other strokes deliverable on request.

Technical data of crank drive

Stroke: 300 mm from 780 mm up to 1080 mm
or
400 mm from 780 mm up to 1180 mm
Load on table: 220 kg maximum, 350 kg (alternatively)
Lifting speed: approx. 5 mm per turn of the crank (*)
Drive: 4 hydraulic cylinders integrated in the legs, with pump and crank, can be folded down. The crank being folded-in disappears completely underneath the work top.
Radius of crank: 125 mm

(*) The lifting speed may slightly vary depending on the load on the table.

Technical data of electric drive:

Stroke: 280 mm from 780 mm up to 1060 mm
or 380 mm from 780 mm up to 1160 mm
Load on table: 220 kg maximum, 350 kg (alternatively)
Lifting speed: approx. 30 mm/s with a load on table of 220 kg approx. 15 mm/s with a load on table of 350 kg
Drive: 4 Hydraulikzylinder in FüÙe systemadäquat integriert, mit Pumpe und Elektromotor, Sicherung vor Überlast inkl.
Note regarding duty cycle: The drive is designed for permanent operation. When using the maximum load, the drive needs a break of approx. 20 min. after 1 min. running. It is protected against overload by a temperature switch.

Stroke	Order No.
100mm	04.18.100
200mm	04.18.200
300mm	04.18.300
400mm	04.18.400

Stroke	Load on table	Order No.
300mm	220 kg	04.18.301
300mm	350kg	04.18.302
400mm	220kg	04.18.401
400mm	350kg	04.18.402

Stroke	Load on table	Order No.
280mm	220 kg	04.18.281
280mm	350kg	04.18.282
380mm	220kg	04.18.381
380mm	350kg	04.18.382

Assembly trolleys

Basic equipment:

Work top and shelves:	Plastic with an angular iron frame, shelf with a rounded-off edge of 5 mm
Steel frame:	Profile pipe 30x2 mm, 4 steering wheels 75 mm Ø, 2 of them lockable, loading capacity 150 kg
Drawer:	Steel, with organizational elements, usable depth 490 mm, partially extendable
Locking:	Safety cylinder for individual and central locking, general locking system on request
Size:	490 x 600 x 780 mm high
Selection of pattern:	See page 10-11
Conductive design as an alternative:	Wheels, top board, base, drawers of conductive design



Assembly trolley:

1 Drawer, front height 3 HE with single extension
1 Shelf

Not conductive design:

Order No. 04.19.0001

Conductive design: 

Order No. 04.19.0002

Additional price for full drawer extension:

Order No. 04.19.0020



Assembly trolley:

1 Drawer, front height 3 HE with single extension

2 Shelves

Not conductive design:

Order No. 04.19.0003

Conductive design: 

Order No. 04.19.0004



Assembly trolley:

2 Drawers, front height 3 HE with single extension

1 Shelf

Not conductive design:

Order No. 04.19.0005

Conductive design: 

Order No. 04.19.0006



Assembly trolley:

2 Drawers, front height 3 HE with single extension

1 Drawer, front height 5 HE with full extension

Not conductive design:

Order No. 04.19.0007

Conductive design: 

Order No. 04.19.0008

Side tables with a shelf

4 different side tables are available for designing and completion of working places. On request, shelves can be set back.

Basic equipment:

Table top:	approx. 30 mm thick, with a plastic banding all around
Steel frame:	Profile pipe 40 x 2 mm, solidly welded with welded-on legs
Shelves:	Laminated on both sides, welded-in angular profiles
Sliding doors:	Suspended design placed on roller bearings, made of plastics
Locking:	Safety cylinder, individual locking, main locking system. on request
Selection pattern:	See page 10-11
Conductive design:	For conductive side tables the work top is volume conductive. All other components such as shelves and cabinets with sliding doors are not conductive of this design. On request, all components are available as conductive design.



Type 20.1 Standard
Type 20.2 Conductive design



Typ 20.3 Standard
Typ 20.4 Conductive design



Typ 20.5 Standard
Typ 20.6 Conductive design



Typ 20.7 Standard
Typ 20.8 Conductive design





Movable

All side tables can be completed by steering wheels. For the types 20.1 and 20.2 a reinforcement of the bottom frame will be necessary. On request, movable tables can be equipped with lateral handles.



Options:

Reinforced bottom frame	At the side and back for tables type 20.1 and 20.2	04.20.9001
Reinforced bottom frame	At the side and back for tables type 20.1 and 20.2	04.20.9002
V2A glider	 for EGB table instead of discharge connection	04.20.9003
Steering wheels	∅ 100 mm, 2 of them fixable, standard	04.20.9004
Steering wheels	∅ 100 mm, 2 of them completely fixable, standard	04.20.9005
Steering wheels	∅ 100 mm, 2 of them completely fixable, EGB	04.20.9006
Steering wheels	∅ 125 mm, 2 of them completely fixable, standard	04.20.9007
Steering wheels	∅ 125 mm, 2 of them completely fixable, EGB	04.20.9008
Fixation for steering wheels	∅ 100 mm	04.20.9009
Complete fixation for steering wheels	∅ 100 mm and ∅ 125 mm	04.20.9010
Handle	at the left or right (please indicate in your order)	04.20.9011

Type of table	Width of table	Design	Order No. Depth 400	Order No. Depth 600	Order No. Depth 800	Order No. Depth 900	Order No. Depth 1000
20.1	800	Standard	04.20.1084	04.20.1086	04.20.1088	04.20.1089	04.20.1081
	1000		04.20.1104	04.20.1106	04.20.1108	04.20.1109	04.20.1101
	1200		04.20.1124	04.20.1126	04.20.1128	04.20.1129	04.20.1121
	1600		04.20.1164	04.20.1166	04.20.1168	04.20.1169	04.20.1161
	1800		04.20.1184	04.20.1186	04.20.1188	04.20.1189	04.20.1181
	2000		04.20.1204	04.20.1206	04.20.1208	04.20.1209	04.20.1201
20.2	800	EGB/ESD 	04.20.2084	04.20.2086	04.20.2088	04.20.2089	04.20.2081
	1000		04.20.2104	04.20.2106	04.20.2108	04.20.2109	04.20.2101
	1200		04.20.2124	04.20.2126	04.20.2128	04.20.2129	04.20.2121
	1600		04.20.2164	04.20.2166	04.20.2168	04.20.2169	04.20.2161
	1800		04.20.2184	04.20.2186	04.20.2188	04.20.2189	04.20.2181
	2000		04.20.2204	04.20.2206	04.20.2208	04.20.2209	04.20.2201
20.3	800	Standard	04.20.3084	04.20.3086	04.20.3088	04.20.3089	04.20.3081
	1000		04.20.3104	04.20.3106	04.20.3108	04.20.3109	04.20.3101
	1200		04.20.3124	04.20.3126	04.20.3128	04.20.3129	04.20.3121
	1600		04.20.3164	04.20.3166	04.20.3168	04.20.3169	04.20.3161
	1800		04.20.3184	04.20.3186	04.20.3188	04.20.3189	04.20.3181
	2000		04.20.3204	04.20.3206	04.20.3208	04.20.3209	04.20.3201
20.4	800	EGB/ESD 	04.20.4084	04.20.4086	04.20.4088	04.20.4089	04.20.4081
	1000		04.20.4104	04.20.4106	04.20.4108	04.20.4109	04.20.4101
	1200		04.20.4124	04.20.4126	04.20.4128	04.20.4129	04.20.4121
	1600		04.20.4164	04.20.4166	04.20.4168	04.20.4169	04.20.4161
	1800		04.20.4184	04.20.4186	04.20.4188	04.20.4189	04.20.4181
	2000		04.20.4204	04.20.4206	04.20.4208	04.20.4209	04.20.4201
20.5	800	Standard	04.20.5084	04.20.5086	04.20.5088	04.20.5089	04.20.5081
	1000		04.20.5104	04.20.5106	04.20.5108	04.20.5109	04.20.5101
	1200		04.20.5124	04.20.5126	04.20.5128	04.20.5129	04.20.5121
	1600		04.20.5164	04.20.5166	04.20.5168	04.20.5169	04.20.5161
	1800		04.20.5184	04.20.5186	04.20.5188	04.20.5189	04.20.5181
	2000		04.20.5204	04.20.5206	04.20.5208	04.20.5209	04.20.5201
20.6	800	EGB/ESD 	04.20.6084	04.20.6086	04.20.6088	04.20.6089	04.20.6081
	1000		04.20.6104	04.20.6106	04.20.6108	04.20.6109	04.20.6101
	1200		04.20.6124	04.20.6126	04.20.6128	04.20.6129	04.20.6121
	1600		04.20.6164	04.20.6166	04.20.6168	04.20.6169	04.20.6161
	1800		04.20.6184	04.20.6186	04.20.6188	04.20.6189	04.20.6181
	2000		04.20.6204	04.20.6206	04.20.6208	04.20.6209	04.20.6201
20.7	800	Standard	04.20.7084	04.20.7086	04.20.7088	04.20.7089	04.20.7081
	1000		04.20.7104	04.20.7106	04.20.7108	04.20.7109	04.20.7101
	1200		04.20.7124	04.20.7126	04.20.7128	04.20.7129	04.20.7121
	1600		04.20.7164	04.20.7166	04.20.7168	04.20.7169	04.20.7161
	1800		04.20.7184	04.20.7186	04.20.7188	04.20.7189	04.20.7181
	2000		04.20.7204	04.20.7206	04.20.7208	04.20.7209	04.20.7201
20.8	800	EGB/ESD 	04.20.8084	04.20.8086	04.20.8088	04.20.8089	04.20.8081
	1000		04.20.8104	04.20.8106	04.20.8108	04.20.8109	04.20.8101
	1200		04.20.8124	04.20.8126	04.20.8128	04.20.8129	04.20.8121
	1600		04.20.8164	04.20.8166	04.20.8168	04.20.8169	04.20.8161
	1800		04.20.8184	04.20.8186	04.20.8188	04.20.8189	04.20.8181
	2000		04.20.8204	04.20.8206	04.20.8208	04.20.8209	04.20.8201

System components for the assembly world

Universal assembly extension arm

- consisting of two high-quality aluminium system profiles inclusive fastening material
- for installing working place lamps, rails and universal compressed air supply lines

	Order No.
Universal assembly extension arm	04.22.100



Rail with tool carriage

- for installing balancers for air operated and electric tools
- steplessly adjustable in depth

Width of table	Order No.
1200 mm	04.22.1112
1600 mm	04.22.1116
1800 mm	04.22.1118
2000 mm	04.22.1120



Universal compressed air supply rail

- for connecting several air-operated tools
- steplessly adjustable in depth

	Couplings / Order No.
Width of table	4 Pcs.
1200 mm	04.22.1212
1600 mm	04.22.1216
1800 mm	04.22.1218
2000 mm	04.22.1220
Width of table	6 Pcs.
1200 mm	04.22.1312
1600 mm	04.22.1316
1800 mm	04.22.1318
2000 mm	04.22.1320



Accessories

Air-operated couplings at the assembly extension arm

- for the direct connection of air-operated tools

	Order No.
Connection at the left	04.22.1401
Connection at the right	04.22.1402

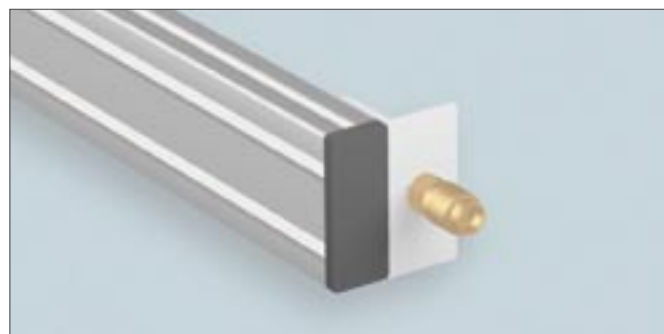

Accessories: Balancer

Article	Adjustable load	Length of extension arm	Order No.
Balancer with cable pull	0,2 - 0,7 kg	2,2 m	04.22.1410
	0,7 - 1,4 kg	2,2 m	04.22.1411
	1,4 - 2,3 kg	2,2 m	04.22.1412
Balancer with cable pull and compressed air spiral hose	0,5 - 1,0 kg	0,95 m	04.22.1413
	1,0 - 2,0 kg	0,95 m	04.22.1414
	1,2 - 2,5 kg	1,35 m	04.22.1415

Article	Usable working length	Outside spiral	Order No.
Compressed air spiral hose	2,5 m	Ø 110 mm	04.22.1416
	5,0 m	Ø 110 mm	04.22.1417
	7,5 m	Ø 110 mm	04.22.1418



Aluminium swivel lamp, light-gray RAL 7035

- inclinable and turnable
- reflector grid
- inclusive swivel arm and universal adapter

Width of lamp (power)	Fluorescent lamp ballast / Order No.	
	electronic	conventional
490 mm (1x36W)	04.22.1501	04.22.1502



Lighting systems



Aluminium lamp with pull cable, light-gray RAL 7035

inclusive lamp holder, steplessly adjustable in depth, length of extension 300 - 1360 mm, reflector grid

Width of lamp (power)	Width of table	Fluorescent lamp ballast / Order No.	
		electronic	conventional
910 mm (2x36W)	1200 mm	04.22.1510	04.22.1518
	1600 mm	04.22.1511	04.22.1519
	1800 mm	04.22.1512	04.22.1520
	2000 mm	04.22.1513	04.22.1521
1120 mm (2x40W)	1200 mm	04.22.1514	-
	1600 mm	04.22.1515	-
	1800 mm	04.22.1516	-
	2000 mm	04.22.1517	-



Aluminium working place lamp, light-gray RAL 7035

inclusive lamp holder, steplessly adjustable in depth, reflector grid

Width of lamp (power)	Width of table	Fluorescent lamp ballast / Order No.	
		electronic	conventional
910 mm (2x36W)	1200 mm	04.22.1522	04.22.1531
	1600 mm	04.22.1523	04.22.1532
	1800 mm	04.22.1524	04.22.1533
	2000 mm	04.22.1525	04.22.1534
1120 mm (2x40W)	1200 mm	04.22.1526	-
	1600 mm	04.22.1527	-
	1800 mm	04.22.1528	-
	2000 mm	04.22.1529	-
1920 mm (3x36W)	1200 mm	-	-
	1600 mm	-	-
	1800 mm	-	-
	2000 mm	04.22.1530	04.22.1535

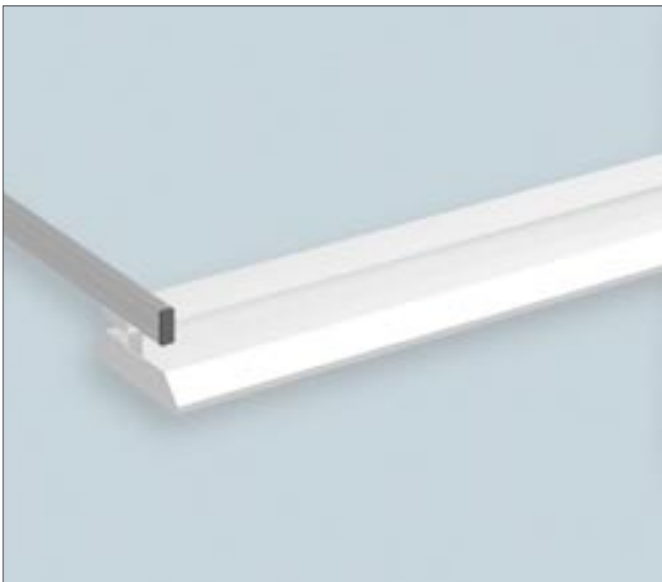

Economy working place lamp

inclusive lamp holder, steplessly adjustable in depth, lamella grid made of sheet steel

Width of lamp (power)	Width of table	Order No.
1225 mm (2x36W)	1200 mm	04.22.1536
	1600 mm	04.22.1537
	1800 mm	04.22.1538
	2000 mm	04.22.1539
1525 mm (2x58W)	1200 mm	-
	1600 mm	04.22.1540
	1800 mm	04.22.1541
	2000 mm	04.22.1542

Lighting systems

Point light lamp

- Lamp body made aluminium with heat protection casing
- Equipment: Halogen lamp 20 W, lamp covering made of glass
- Lamp body \varnothing 71 x 80 mm black
- Rods 280 + 425 mm, stone-gray RAL 7030
- Voltage: 230 V, 50/60 Hz
- Built-in transformer

Design	with table leg	With universal adapter for the lateral fastening to an aluminium leg
Order No.	04.22.1601	04.22.2.1602



Fan lamp

- Lamp body made of plastics
- Equipment: Ring lamp 22 W
- Lamp body \varnothing 247 mm, light-gray RAL 7035
- Rods 410 + 410 mm, light-gray RAL 7035
- Voltage: 230 V, 50 Hz
- Built-in fluorescent lamp ballast
- Fan for separate switching on/off and freely blowing, equipped with an active carbon filter

Design	with table leg	With universal adapter for the lateral fastening to an aluminium leg
Order No.	04.22.1604	04.22.1605

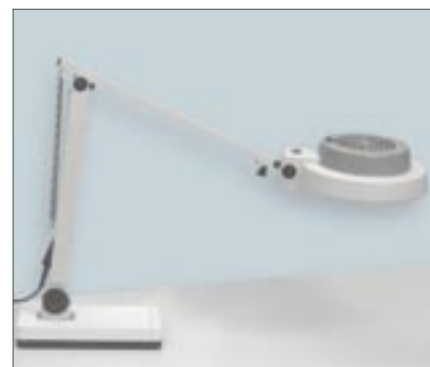

Magnifying lamp

- Lamp body made of plastics
- Equipment: Compact LS lamp 11 watt
- Lamp body 270 x 67 x 52 mm, gray-white approx. RAL 9002
- Rods 400 + 420 mm, gray-white approx. RAL 9002
- Voltage: 230 V, 50 Hz.
- Plug-type fluorescent lamp ballast
- Magnifying glass 4 diopters, \varnothing 120 mm

Design	with table leg	With universal adapter for the lateral fastening to an aluminium leg
Order No.	04.22.1607	04.22.1608



Office and computer working places

- Lamp body made of plastics
- Equipment: 2 compact LS lamps 9 watt
- Lamp body 223 x 210 x 57 mm, dust-gray RAL 7037
- Rods 445 + 400 mm, light-gray RAL 7035
- Voltage: 230 V, 50 Hz
- Plug-type fluorescent lamp ballast

Design	with table leg	With universal adapter for the lateral fastening to an aluminium leg
Order No.	04.22.1610	04.22.1611



Perforated sheet metal walls and accessories

Sheet metal wall

- with square holes
- for installation between two aluminium leg profiles

Size of perforated plate (width x height)	Order No. light-gray RAL 7035	Order No. gentian-blue RAL 5010
502 x 449 mm	04.22.1701	04.22.1705
996 x 449 mm	04.22.1702	04.22.1706
1490 x 449 mm	04.22.1703	04.22.1707
1986 x 449 mm	04.22.1704	04.22.1708

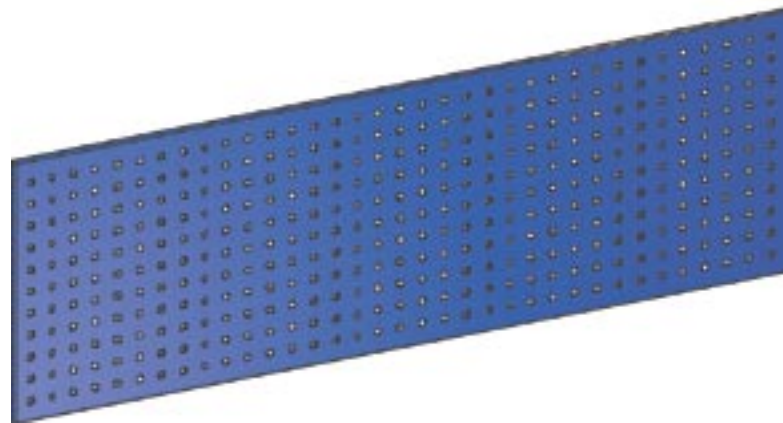

Accessories

for suspension in the sheet metal walls



Simple hook Ø 6 mm

Length of hook	Order No.
35 mm	04.22.1711
75 mm	04.22.1712
125 mm	04.22.1713



Double hook Ø 6 mm

Length of hook	Order No.
35 mm	04.22.1714
50 mm	04.22.1715
75 mm	04.22.1716
150 mm	04.22.1717



Simple tool clamp Ø

Order No.	
6 mm	04.22.1719
10 mm	04.22.1720
13 mm	04.22.1721
16 mm	04.22.1722
19 mm	04.22.1723
25 mm	04.22.1724
28 mm	04.22.1725
32 mm	04.22.1726



Double tool clamp

Order No.	
6 mm	04.22.1727
10 mm	04.22.1728
13 mm	04.22.1729
16 mm	04.22.1730
19 mm	04.22.1731

Storage tray



Size	Order No.
350 x 125 x 12 mm	04.22.1732
445 x 150 x 12 mm	04.22.1733



Tin holder Ø 70 mm

for	Size	Order No.
1 tin	100 x 90 x 70 mm	04.22.1734
3 tins	300 x 90 x 70 mm	04.22.1735



Unrolling holder

Size	Order No.
360 x 100 x 120 mm	04.22.1736



Hose holder

Size	Order No.
230 x 125 x 100 mm	04.22.1737



Tool holder for 6 screwdrivers

Size	Order No.
200 x 30 x 30 mm	04.22.1738



Pipe holder

Order No.	
60 mm	04.22.1739
100 mm	04.22.1740



Maintenance unit for the preparation of compressed air

Order No.
04.22.1741

Bowls, cases, tongues

Bowls



Cases

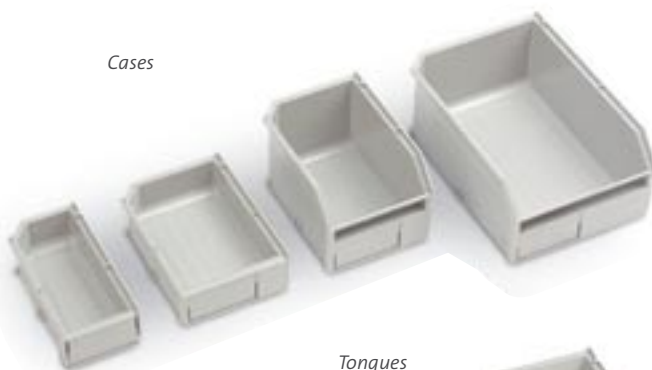

Tongues



Bowls, cases, tongues made of plastics

- Colour: light-gray (not conductive), black (conductive)
- Resistant against: slight acids, lye, alcohol, grease, oil, water



Article	Size (widthxdepthxheight)	Contents (litres)	Order No.	
			conductive not	conductive
Bowl	82 x 86 x 50 mm	0,15 l	04.22.1801	04.22.1802
	123 x 86 x 50 mm	0,24 l	04.22.1803	04.22.1804
	173 x 86 x 50 mm	0,36 l	04.22.1805	04.22.1806
Case	82 x 173 x 50 mm	0,37 l	04.22.1810	04.22.1811
	123 x 173 x 50 mm	0,60 l	04.22.1812	04.22.1813
	123 x 173 x 100 mm	1,37 l	04.22.1814	04.22.1815
	173 x 245 x 100 mm	3,05 l	04.22.1816	04.22.1817
Cover for case	77 x 173 x 13 mm	-	04.22.1820	04.22.1821
	117 x 173 x 13 mm	-	04.22.1822	04.22.1823
	117 x 173 x 32 mm	-	04.22.1824	04.22.1825
	167 x 245 x 32 mm	-	04.22.1826	04.22.1827
Tongue	90 x 277 x 54 mm	0,69 l	04.22.1830	04.22.1831
	131 x 277 x 54 mm	1,05 l	04.22.1832	04.22.1833

Accessories for cases:

(suitable for all 4 sizes)

Fastening clip for labels

Order No. 04.22.1840 (10 pcs.)

Labels, lined

Order No. 04.22.1841 (10 pcs.)



Horizontal holding profile

Width of table	Order No.
1200 mm	04.22.1850
1600 mm	04.22.1851
1800 mm	04.22.1852
2000 mm	04.22.1853

Universal profile frame with displaceable shelves for the cases

Width of table	Order No.
1200 mm	04.22.1855
1600 mm	04.22.1856
1800 mm	04.22.1857
2000 mm	04.22.1858



Labels for visual stock boxes

10 pcs. each

suitable for type	Order No.
1	04.22.0001
2, 3, 4, 5	04.22.0002



Visual stock boxes made of plastics

- Colour: blue (not conductive), black (conductive)
- resistant against most acids and lyes
- Temperature resistant between -40° and +80° C

Design	Type	Size (width x Contents)		Order No.
		depth x height)	(litres)	
not conductive	1	100 x 160 x 75 mm	0,80 l	04.22.1860
	2	150 x 230 x 130 mm	2,60 l	04.22.1861
	3	220 x 350 x 200 mm	10,4 l	04.22.1862
	4	320 x 500 x 200 mm	23,5 l	04.22.1863
	5	470 x 520 x 300 mm	57,0 l	04.22.1864
conductive (ESD)	1	95 x 160 x 76 mm	0,80 l	04.22.1865
	2	150 x 230 x 120 mm	2,60 l	04.22.1866
	3	200 x 350 x 200 mm	10,0 l	04.22.1867
	4	300 x 510 x 200 mm	23,0 l	04.22.1868

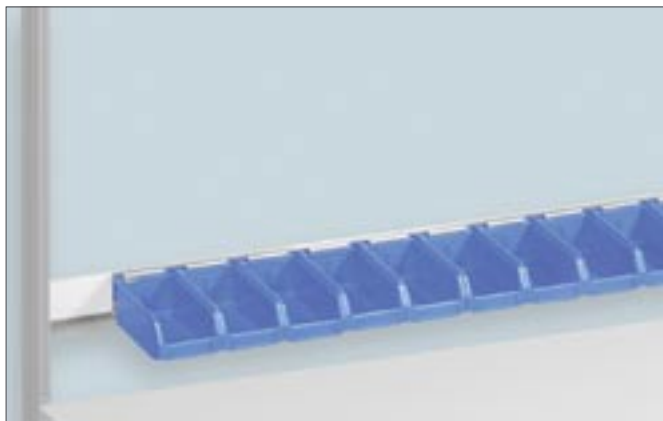

Holding rails for visual stock boxes

steplessly adjustable in height, scope of supply without container

Visual stock box	Width of table	Number of boxes	Order No.
Type 1	1200 mm	10	04.22.1870
	1600 mm	11	04.22.1871
	1800 mm	11	04.22.1872
	2000 mm	11	04.22.1873
Type 2	1200 mm	6	04.22.1874
	1600 mm	7	04.22.1875
	1800 mm	7	04.22.1876
	2000 mm	7	04.22.1877

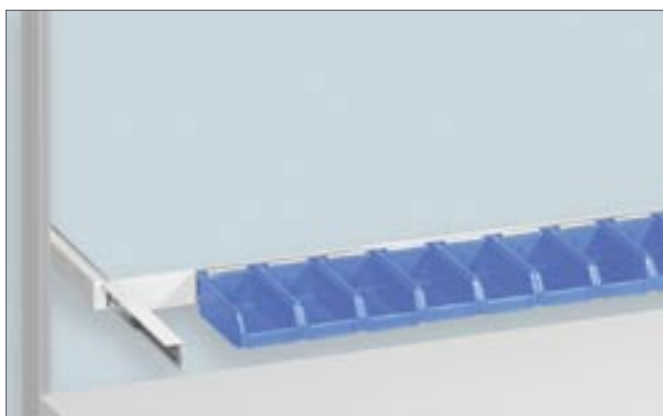

Depth adjustable holding rail for visual stock boxes

withdrawable to the front by 250 mm, steplessly adjustable in height, scope of supply without container

Visual stock box	Width of table	Number of boxes	Order No.
Type 1	1200 mm	10	04.22.1970
	1600 mm	11	04.22.1971
	1800 mm	11	04.22.1972
	2000 mm	11	04.22.1973
Type 2	1200 mm	6	04.22.1974
	1600 mm	7	04.22.1975
	1800 mm	7	04.22.1976
	2000 mm	7	04.22.1977

High-quality swiveling technique

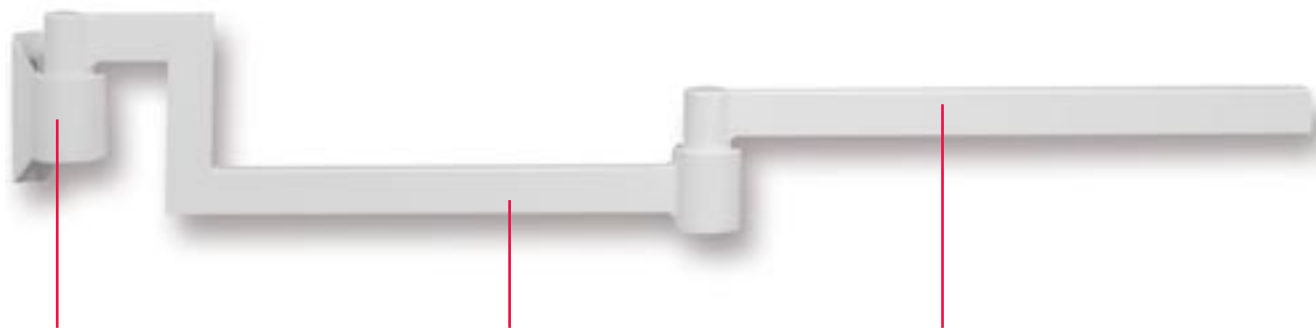

Universal adapter

Order No. 04.23.001

- for the quick and simple adaptation to the aluminium leg system profile
- designed for heavy loads
- steplessly adjustable in height



Auxiliary swivel arm

Order No. 04.23.002

- the solid round bolt is directly plugged in the universal adapter
- the basic swivel arm is



Basic swivel arm

Order No. 04.23.003

- Designed as single swivel arm (see small photograph below): the solid round bolt is directly plugged in the universal adapter
- Designed as double swivel arm (see big photograph below): the solid round bolt is directly plugged in the auxiliary swivel arm
- the swiveling elements can be fitted at the other end of the swivel arm



Swiveling elements



Holding frame type 1 for visual stock boxes

Design	for visual stock boxes	Number of boxes	Order No.
Single-sided fitting	Type 1	15	04.23.010
	Type 2	6	04.23.011
Double-sided fitting	Type 1	30	04.23.012
	Type 2	12	04.23.013



Holding frame type 2 for visual stock boxes

Design	for visual stock boxes	Number of boxes	Order No.
Single-sided fitting	Type 1	7	04.23.020

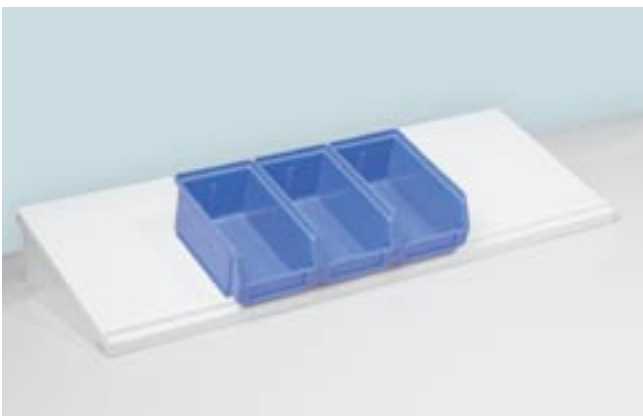

Inclined tray for visual stock boxes

- is directly placed on the work top
- rubber buffers at the underside avoid an unintentional displacement

Design	for visual stock boxes	Number of boxes	Order No.
Single-sided fitting	Type 1	6	04.23.025
	Type 2	4	

Storage plates, circular storage plates, documentation

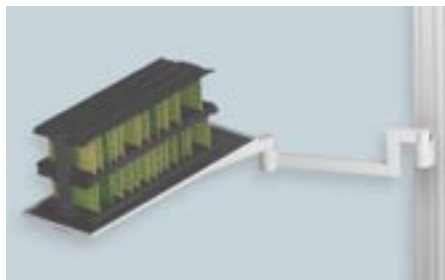

Swiveling storage plate

- inclusive rubber mat
- for preparing material, accessories etc.

Size (width x depth)	Order No.
700 x 250 mm	04.23.030
600 x 400 mm	04.23.031

Note:

For swiveling storage plates, circular storage plates and information boards, please indicate separately the universal adapter and the swivel arms listed on page 57.



Circular storage plate 360°

- for small items

Size (width x depth)	Order No.
not conductive	04.23.032
conductive (ESD)	04.23.033



Information board

- inclusive 4 solenoids
- slewable to the back by 90°

Size (width x depth)	Order No.
DIN A4 high	04.23.034
DIN A4 transverse	04.23.035
DIN A3 high	04.23.036
DIN A3 transverse	04.23.037



Holder for foil bags

Order No. 04.23.038

- with 10 foils DIN A4 for documents
- optionally for the direct fastening to the table top or to the aluminium leg system profile by means of the universal adapter

Others



Cable comb

for approx. 40 laboratory cords
Order No.
04.23.039



Holder for measuring lines, slewable by 180°

- optionally equipped at one or two sides with:
- 1 hose holder with 3 depositing possibilities
 - 1 laboratory cord holder 300 mm long with 21 supporting elements

Design	Order No.
Single-sided fitting	04.23.040
Double-sided fitting	04.23.041

Others



Bottle holder

- for bottles and square drinks
- steel wire, light-gray, coated with plastics

Order No. 04.23.042



Cup holder

- for cups and beakers
- plastic, black

Order No. 04.23.043



Hook for accessories

- length 50 mm
- Ø 6 mm
- Steel

Order No. 04.23.044

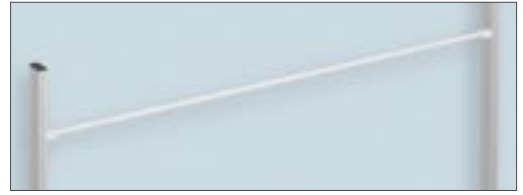

Cable roll holder

- for installation between two aluminium leg system profiles of an ABZ table
- steplessly adjustable in height
- removable bar Ø 18 mm

Width of table	Order No.
1200 mm	04.23.047
1600 mm	04.23.048
1800 mm	04.23.049
2000 mm	04.23.050

Waste paper basket with separating system, 18 litres

- inclusive adapter and swivel arm (380 mm long)
- waste paper basket inclusive 2 inserts 2,2 litres and 2 hinged



Pattern	Order No.
Waste paper basket light-gray	
2 Inserts stone-gray	04.23.045
1 Hinged lid gray	
1 Hinged lid green	
Waste paper basket black	
2 Inserts black	04.23.046
1 Hinged lid gray	
1 Hinged lid green	

Ergonomic foot rests



Model 1 (not conductive)

- colour black-chrome
- chromium-plated rack on non-skidding rubber legs
- solid base plate, simply adjustable by the push of the foot
- height adjustment 50 – 100 mm



Model 2 (not conductive, alternatively conductive)

- colour black
- adjustable by an inclination fitted at the underside
- with the conductive design the foot rest can be connected directly to the earthing potential by an earthing point, leak 10 MΩ
- height adjustment at the front 30-00 mm, at the back 70-175 mm



Model 3 (not conductive and conductive resp.)

- directly connected with the table, fits optimally in shape and function to the table system
- steplessly inclinable and horizontally displaceable
- height adjustable
- leak 10 MΩ

Design	Order No.	
	not conductive	conductive
Model 1	04.23.051	-
Model 2	04.23.052	04.23.053
Model 3	04.23.054	04.23.055



Electric energy supply



horizontal attachment for multiple connector strips

- for installation to two aluminium leg system profiles of an ABZ table
- steplessly adjustable in height
- for the lateral insertion of multiple connector strips
- with two openings for the feedthrough of mains supply lines



Cable tray

Ideal for placing-in a large amount of cables and multiple connector strips. Accessible from the front, open at the sides for the optimal feedthrough. Optionally directly connected with the steel frame or adjustable in height at the aluminium leg profile adapted at the back.



Size: Usable height: 160 mm, depth of groove: 160 mm, edged at the front: 40 mm

Cable tray fitted directly to the steel frame

Width of table	Order No.
1200mm	04.23.070
1600mm	04.23.071
1800mm	04.23.072
2000mm	04.23.073

Cable tray fitted to the aluminium leg profile, adjustable in height

Tischbreite	Order No.
1200mm	04.23.074
1600mm	04.23.075
1800mm	04.23.076
2000mm	04.23.077

Width of table	Order No.
1200 mm	04.23.060
1600 mm	04.23.061
1800 mm	04.23.062
2000 mm	04.23.063



Multiple connector strips

- casing made of shockproof PP, free from chlorine and halogene
- shockproof sockets DIN 49440, 250 V ~, 16 A
- connection line 2 m with shockproof angular plug
- arrangement of sockets 45°
- colour anthracite-gray similar to RAL 7016

Multiple connector strips with overvoltage protection, 16 A

- casing made of shockproof PP, free from chlorine and halogene
- shockproof sockets DIN 49440, 250 V ~, 16 A
- connection line 2 m
- arrangement of sockets 45°
- colour anthracite-gray similar to RAL 7016
- with optical danger signal

Industrial multiple connector strips

- casing made of shockproof PP, free from chlorine and halogene
- shockproof sockets DIN 49440, 250 V ~, 16 A
- connection line 2 m with shockproof angular plug
- arrangement of sockets 45°
- colour orange similar to RAL 2004

Design	Sockets	Width of strip	Order No.
without switch	5-fold	384 mm	04.23.080
	6-fold	428 mm	04.23.081
with switch, 2 poles, illuminated	5-fold	384 mm	04.23.082
	6-fold	428 mm	04.23.083

Design	Sockets	Width of strip	Order No.
with switch, 2 poles, illuminated, without supply filter	5-fold	472 mm	04.23.084
	6-fold	516 mm	04.23.085
with switch, 2 poles, illuminated, with supply filter	5-fold	560 mm	04.23.086
	6-fold	604 mm	04.23.087

Design	Sockets	Width of strip	Order No.
without switch	3-fold	296 mm	04.23.088
with switch, 2 poles, illuminated	3-fold	296 mm	04.23.089

Electric energy supply

Vertical aluminium energy channel

- for fitting to the aluminium leg profile
- 5 designs available



Design 1:

- 4 x shockproof socket 230 V/50 Hz
- acoustical continuity tester
- compressed air connection
- On/off switch for the light at the universal assembly extension arm or for another consumer point at the working place

Order No. 04.23.090



Design 2:

- 4 x shockproof socket 230 V/50 Hz
- RJ 45 double socket CAT 6, not wired
- compressed air connection
- On/off switch for the light at the universal assembly extension arm or for another consumer point at the working place

Order No. 04.23.091



Design 3:

- fuse protection unit:
Emergency shut-off push-button,
room emergency shut-off prepared,
motor protection switch 10-16A with
built-in undervoltage release,
NFI switch, leakage current 30 mA,
nominal current 25 A
- 2 x shockproof socket 230 V/50 Hz
- compressed air connection
- On/off switch for the light at the universal assembly extension arm or for another consumer point at the working place

Order No. 04.23.092



Design 4:

- fuse protection unit:
Emergency shut-off push-button,
room emergency shut-off prepared,
motor protection switch 10-16A with
built-in undervoltage release,
NFI switch, leakage current 30 mA,
nominal current 25 A
- 2 x shockproof socket 230 V/50 Hz
- socket without earthing contact by
isolating transformer for taking-out
unearthed alternating voltage 230 V/max.
75 VA, 50 Hz. inclusive safety fuse
- compressed air connection
- On/off switch for the light at the universal assembly extension arm or for another consumer point at the working place

Order No. 04.23.093



Design 5:

- fuse protection unit:
Emergency shut-off push-button,
room emergency shut-off prepared,
motor protection switch 10-16A with
built-in undervoltage release,
NFI switch, leakage current 30 mA,
nominal current 25 A
- shockproof socket 230 V/50 Hz
- acoustical continuity tester
- compressed air connection
- On/off switch for the light at the universal assembly extension arm or for another consumer point at the working place

Order No. 04.23.094

Experiment frames – for installing DIN A4 experiment plates



Experiment frames with extension arm, displaceable in an elongated hole

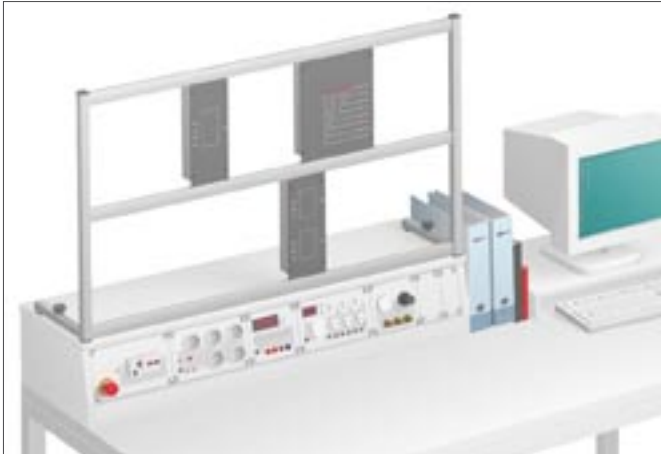
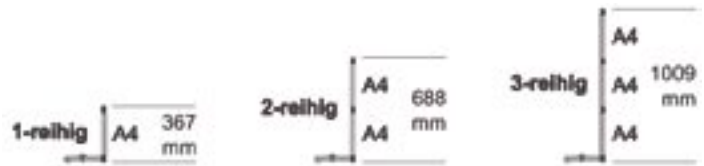

for basic tables and basic tables with attachments

Experiment frames			
Width of table	1 row	2 rows	3 rows
1200 mm	04.25.0121	04.25.0122	04.25.0123
1600 mm	04.25.0161	04.25.0162	04.25.0163
1800 mm	04.25.0181	04.25.0182	04.25.0183
2000 mm	04.25.0201	04.25.0202	04.25.0203

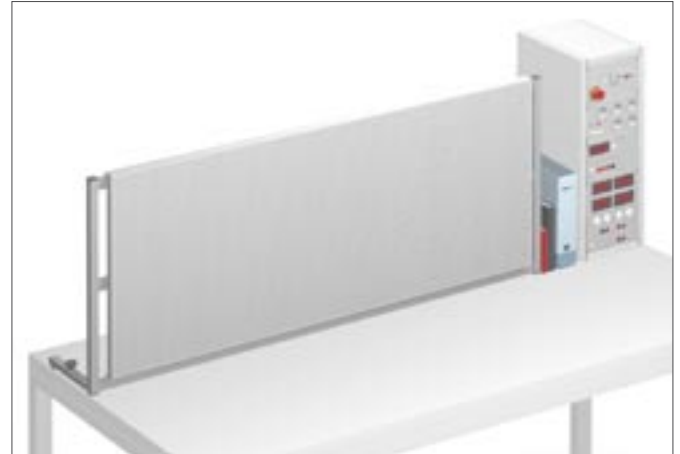

for basic table with 19 inch racks

Width of rack/experiment frame 2 rows			
Width of table	257 mm	328 mm	525 mm
1200 mm	04.25.1122	04.25.1123	-
1600 mm	04.25.1162	04.25.1163	04.25.1165
1800 mm	04.25.1182	04.25.1183	04.25.1185
2000 mm	04.25.1202	04.25.1203	04.25.1205

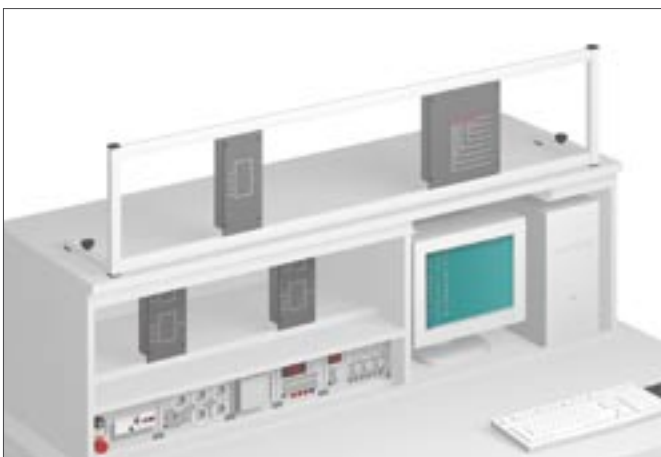

For foldaway tables

Experiment frames			
Width of table	1 row	2 rows	3 rows
1200 mm	04.25.2121	04.25.2122	04.25.2123
1600 mm	04.25.2161	04.25.2162	04.25.2163
1800 mm	04.25.2181	04.25.2182	04.25.2183
2000 mm	04.25.2201	04.25.2202	04.25.2203

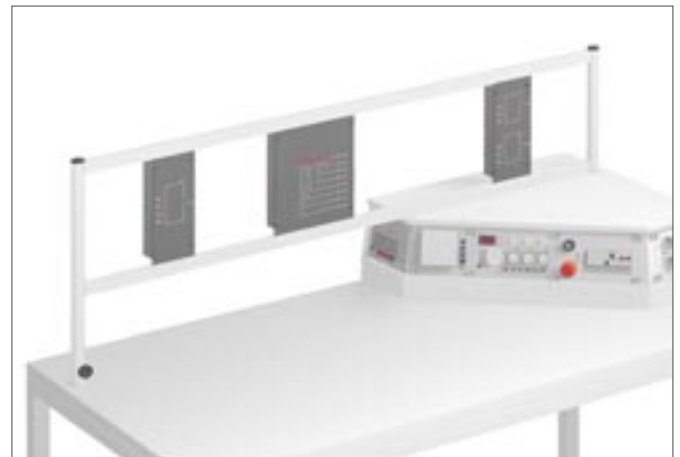

for basic tables with pentagonal / octagonal attachments (to be plugged in Delrin bushings)

Experiment frames		
Width of table	1 row	2 rows
1200 mm	04.25.3121	04.25.3122
1600 mm	04.25.3161	04.25.3162
1800 mm	04.25.3181	04.25.3182
2000 mm	04.25.3201	04.25.3202

Displaceable and variable experiment frames

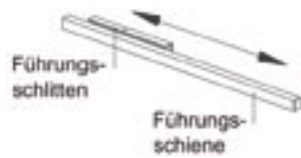
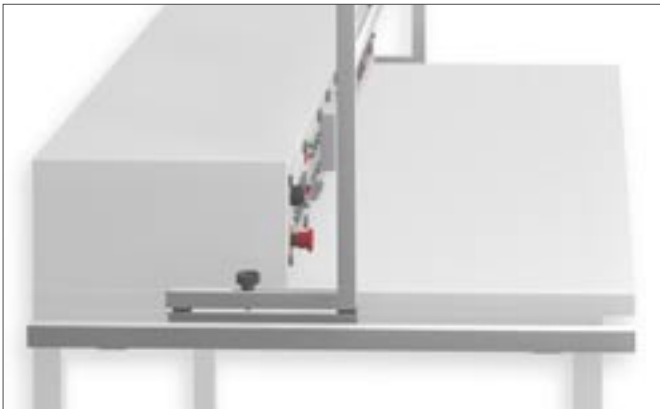

Guide unit, placed on ball bearings

consisting of two guide rails inclusive guide blocks (high-quality ball bearing guide). The experiment frame is installed in the guide unit, leaving free space in the lower part. The design is so chosen that the complete block with the frame can be removed to the front. Due to the mechanical coupling of the guide unit with the experiment frame, complete tests built-up in the frame, can be pushed back to the end of the table.

Depth of table	Guide unit per table
800mm	04.25.6001
900mm	04.25.6002
1000mm	04.25.6003

Experiment frame with free space in the lower part

Ideally suited for direct assembly works on the guide unit. Due to the free space the frame can be displaced to the rear above the table attachment. The frame can also be used in connection with swivel attachments.

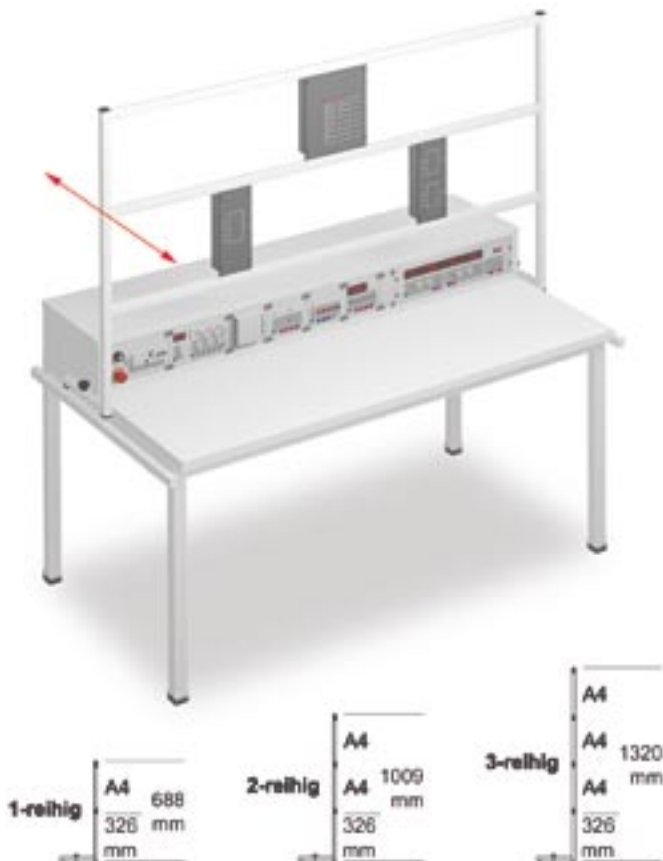

Experiment frames

Width of table	1 row	2 rows	3 rows
1200 mm	04.25.7121	04.25.7122	04.25.7123
1600 mm	04.25.7161	04.25.7162	04.25.7163
1800 mm	04.25.7181	04.25.7182	04.25.7183
2000 mm	04.25.7201	04.25.7202	04.25.7203

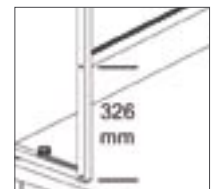



Experiment frames between two aluminium leg profiles

Width of table	Experiment frames		
	1 row	2 rows	3 rows
1200 mm	04.25.4121	04.25.4122	04.25.4123
1600 mm	04.25.4161	04.25.4162	04.25.4163
1800 mm	04.25.4181	04.25.4182	04.25.4183
2000 mm	04.25.4201	04.25.4202	04.25.4203

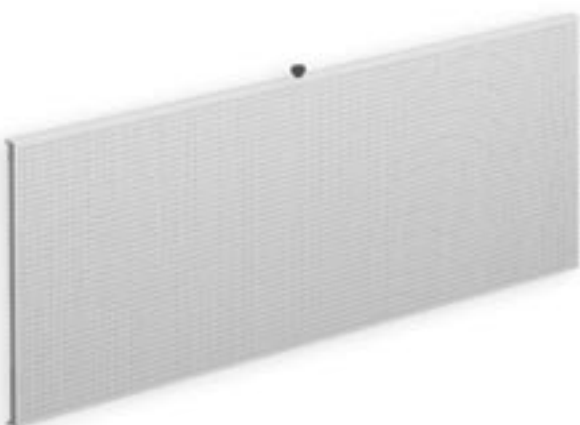

Perforated sheet metal walls

for suspension in experiment frames with 2 rows
inclusive locking button



Size of perforated sheet metal plate	Oval perforation	Rectangular perforation
	14 x 5 mm	10 x 5 mm
670 x 662 mm	04.25.5671	04.25.5672
870 x 662 mm	04.25.5871	04.25.5872
1070 x 662 mm	04.25.5101	04.25.5102
1270 x 662 mm	04.25.5121	04.25.5122
1470 x 662 mm	04.25.5141	04.25.5142
1670 x 662 mm	04.25.5161	04.25.5162
1870 x 662 mm	04.25.5181	04.25.5182

Other sizes available on request.



Fastening kit for perforated sheet metal walls

consisting of:

- 100 special plastic dowels
- 25 Spax screws 3,5 x 12 mm
- 50 Spax screws 3,5 x 20 mm
- 25 Spax screws 3,5 x 30 mm

for oval perforation 14 x 5 mm

Order No. 04.25.5300

for rectangular perforation 10 x 5 mm

Order No. 04.25.5301

Multifunctional classrooms due to innovative ABZ® foldaway tables

A professional driving unit allows changing table functions. The attachments on the table of the most different types can be folded down and retracted again at the working place by the teacher's partitioning or by individual keys. A cut-out bar guar-

antees optimal safety. When operating the safety cut-out bar, an immediate thrust reversal is released. In addition a current control is integrated. In case of overload of the upward movement the drive switches off automatically. A multiple safety device

per function element ensures 100 % safety.

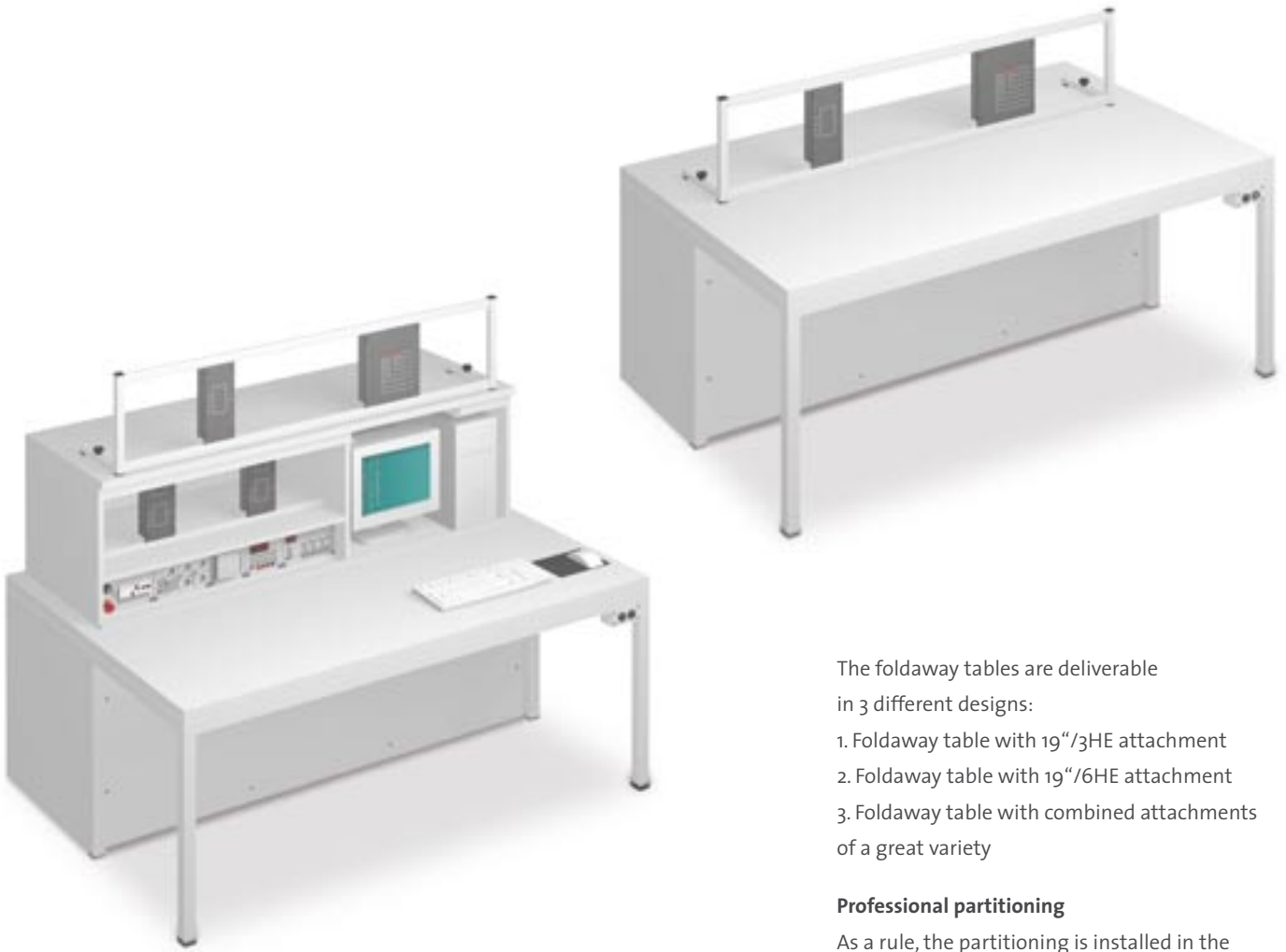

The foldaway tables are deliverable in 3 different designs:

1. Foldaway table with 19"/3HE attachment
2. Foldaway table with 19"/6HE attachment
3. Foldaway table with combined attachments of a great variety

Professional partitioning

As a rule, the partitioning is installed in the teacher's table in a 19" bottom cabinet.

Example of a partitioning:

Equipment from top to bottom:

Control module

Up/down keys per trainee's working place

Central locking module

with key-operated switch, room emergency stop key, motor protection switch, FI-safety switch etc.

Individual network release module

Release of the network for each individual trainee working place by means of a motor protection switch, alternatively by means of a line safety switch



Note:

On request, a remote control can be supplied instead of the up/down keys.



Foldaway attachment 3 HE
inclusive 19" device support

Width of table	TE units	Depth of foldaway unit 490 mm
1200 mm	198 TE	04.26.1203
1600 mm	276 TE	04.26.1603
1800 mm	316 TE	04.26.1803
2000 mm	355 TE	04.26.2003



Foldaway attachment 6 HE
inclusive 19" device support

Width of table	TE units	Depth of foldaway unit 490 mm
1200 mm	198 TE	04.26.1206
1600 mm	276 TE	04.26.1606
1800 mm	316 TE	04.26.1806
2000 mm	355 TE	04.26.2006



Combined foldaway attachment

Top left: 1 row experiment frame for installing
DINA 4 experiment plates

Bottom left: 3 HE, inclusive 19" device support

Right: Storage place for monitor and PC, inclusive keyboard holder

Width of table	Inside width top left	TE units bottom left	Depth of foldaway unit 590 mm
1600 mm	744 mm	141 TE	04.26.1607
1800 mm	944 mm	180 TE	04.26.1807
2000 mm	1144 mm	219 TE	04.26.2007



Double foldaway attachment, separately controlable

Left-hand foldaway attachment:

optionally 3 HE or 6 HE, inclusive 19" device support

Right-hand foldaway attachment:

Storage place for flat screen inclusive keyboard holder

In addition 1 PC bottom cabinet inclusive front door

Security function:

A modern multi-processor

switching guarantees a maximum of security. Processors of reciprocal control monitor permanently the power consumption and the integrated safety cut-out bar.

Width of table	TE units	Foldaway attachment left-hand	Depth of foldaway unit 490 mm
1600 mm	139 TE	3 HE	04.26.1638
		6 HE	04.26.1668
1800 mm	178 TE	3 HE	04.26.1838
		6 HE	04.26.1868
2000 mm	218 TE	3 HE	04.26.2038
		6 HE	04.26.2068

Multi-functional classrooms due to tables with integrated swivel attachments

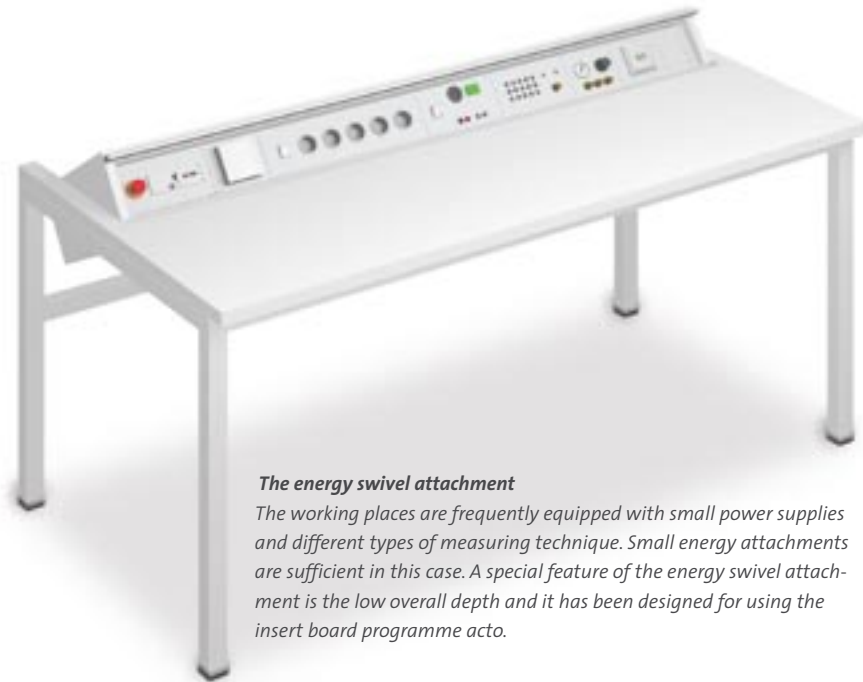

The energy swivel attachment

The working places are frequently equipped with small power supplies and different types of measuring technique. Small energy attachments are sufficient in this case. A special feature of the energy swivel attachment is the low overall depth and it has been designed for using the insert board programme acto.



When retracted the devices disappear completely in the work top.

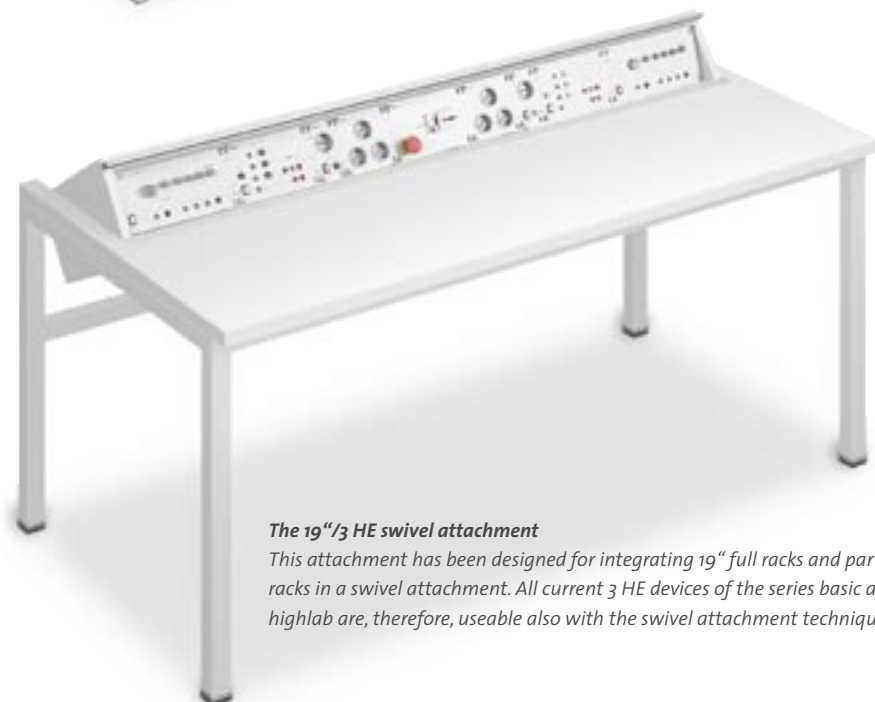

The 19"/3 HE swivel attachment

This attachment has been designed for integrating 19" full racks and partial racks in a swivel attachment. All current 3 HE devices of the series basic and highlab are, therefore, useable also with the swivel attachment technique.

The swivel attachments are available of manual or motorised design as well as in two different models:

1. ABZ tables with energy swivel attachment for the insert board programme acto.
2. ABZ tables with 19"/3 HE swivel attachment for 19" partial and full racks of the equipment programme highlab and basic.

Manual design

With the manual design the attachment can be folded upward by a spring and can be closed again by pressing it downward. A central release at the teacher's place unlocks the swivel attachments.

Motorised design with security function

A microprocessor controlled drive swings the attachment into position without jerks and noise. The double sealing lip at the front of the attachment and the security function guarantee a high safety. The security function monitors the continuous current consumption. In case of excess current the upward movement is immediately stopped and with the downward movement the thrust is reversed. Due to integrated interfaces the swivel attachments can be controlled individually and can be interlinked.

Swivel attachment 700 mm or 900 mm long

Optionally for installing 3 HE devices inclusive 19" device support or for energy insert boards acto. These swivel attachments are available of manual and motorised design.



Size of table	Width of swivel attachment	TE units	For installation of	Manual design	Motorised design
1600 x 800 x 780 mm	700 mm	126 TE	3 HE devices	04.27.1671	04.27.1673
			Insert boards acto	04.27.1672	04.27.1674
	900 mm	168 TE	3 HE devices	04.27.1691	04.27.1693
			Insert boards acto	04.27.1692	04.27.1694
1800 x 800 x 780 mm	700 mm	126 TE	3 HE devices	04.27.1871	04.27.1873
			Insert boards acto	04.27.1872	04.27.1874
	900 mm	168 TE	3 HE devices	04.27.1891	04.27.1893
			Insert boards acto	04.27.1892	04.27.1894
2000 x 800 x 780 mm	700 mm	126 TE	3 HE devices	04.27.2071	04.27.2073
			Insert boards acto	04.27.2072	04.27.2074
	900 mm	168 TE	3 HE devices	04.27.2091	04.27.2093
			Insert boards acto	04.27.2092	04.27.2094

Swivel attachment across the entire width of table

Optionally for installing 3 HE devices inclusive 19" device supports or for energy insert boards acto. These swivel attachments are available of manual and motorised design.



Size of table	For installation of	TE units	Manual design	Motorised design
1200 x 800 x 780 mm	3 HE devices	209 TE	-	04.27.1201
	Insert boards acto	210 TE	04.27.1202	04.27.1203
1600 x 800 x 780 mm	3 HE devices	288 TE	-	04.27.1601
	Insert boards acto	289 TE	04.27.1602	04.27.1603
1800 x 800 x 780 mm	3 HE devices	327 TE	-	04.27.1801
	Insert boards acto	328 TE	04.27.1802	04.27.1803
2000 x 800 x 780 mm	3 HE devices	367 TE	-	04.27.2001
	Insert boards acto	368 TE	04.27.2002	04.27.2003

The octagon and pentagon attachments of 19“/3 HE technique

The octagon attachment of 19“ technique for training in groups and for team works resp. is so designed that each trainee can use the device configuration which was meant for him. The entire medium guidance can invisibly be inserted in the attachment by means of cable channels from the bottom. On request, the medium supply can be made centrally from the ceiling by means of aluminium system profiles which are extended to the top.

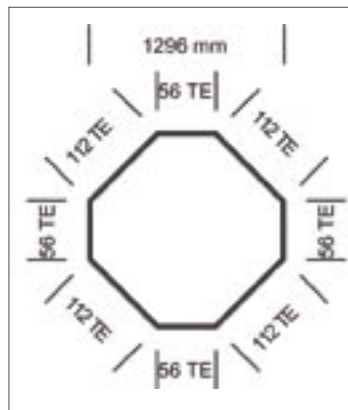

The octagon attachment of 19“/3 HE technique

The medium can invisibly be inserted in the attachment from the floor by means of the central ABZ leg system profile. Octagon attachment 3 HE

1296 x 1296 x 227 mm

Order No. 04.28.800

The octagon attachment inclusive 4-chamber aluminium leg system profile

The medium can invisibly be inserted in the attachment from the ceiling by means of a large-volume 4-chamber aluminium leg system profile. The scope of supply includes in addition: 4-chamber aluminium leg system profile up to a ceiling height of 3,5 m (depending on the ceiling height) inclusive fastening and assembly material for connection to the ceiling. Octagon attachment 3 HE inclusive 4-chamber aluminium leg system profile.

1296 x 1296 x 227 mm

Order No. 04.28.801

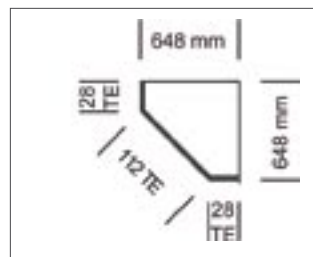

This attachment offers sufficient space for the standard device configuration of a training place. Due to the modular design also individual tables can be set up in a workshop. The pentagon attachment has also been planned for wall mounted working places. These attachments offer for the individual working place the advantages of the octagon attachment. The entire depth of the table can be used by approx. 2/3 of the width of the table inspite of the integration of devices.

Order No. 04.28.500



19" Device rack

inclusive 19" device support

Device support	Width of rack	Order No.
5 x 3 HE/ 42 TE	257 mm	04.29.001
5 x 3 HE/ 56 TE	328 mm	04.29.002
5 x 3 HE/ 70 TE	399 mm	04.29.003
5 x 3 HE/ 84 TE	470 mm	04.29.004
5 x 3 HE/ 19"	525 mm	04.29.005



Suspended drawer units for a double use

Order No. 04.29.010

- This suspended drawer unit can be fitted in the middle, right or left-hand side underneath the working place.
- Two different locks guarantee the strict assignment of the drawers.
- An additional intermediate board avoids the access to the drawer of another trainee.
- Recommended minimum width of the table: 1800 mm



Suspended drawer units, adjustable in depth

can easily be displaced to the rear by a high-quality guide on ball bearing. This creates sufficient leg-room at the front for an additional person. Recommended minimum width of the table with suspended container units which are adjustable in depth: 900 mm

Additional price per drawer unit

Depth of table	Order No.
900 mm	04.29.020
1000 mm	04.29.021



The cabinet systems varantec®pro and varantec®select

Groupe 1: Basic cabinets

With the cabinet systems varantec®pro and varantec®select all possible applications in a company can be materialized.

varantec®pro

The basic programme for highest demands on quality in the fields of application engineering, laboratory and office.

varantec®select

This cabinet programme represents the modern aluminium cabinet system line for highest demands on functionality and aesthetics.

Note:

The detailed technical data of both these cabinet systems are contained in the big coloured catalogue „varantec® - The working place system without compromise“ from page 142 as well as in the detailed order catalogue „varantec® - System components“ from page 116. The cabinets shown therein are only a few selected examples and due to the enormously efficient system components can be combined individually.



varantec®pro basic cabinet

Double cabinet with wing doors

Figure: Pattern beech, top with basic edge, elegant segment handles, chromium-plated, equipped with 3 shelves, high-quality 270° door armatures requiring a minimum of space

Size: 840 x 600 x 1200 mm (width x depth x height)



varantec®pro basic cabinet

Individual cabinet with drawers of the compact drawer system DIN A4 partitioning of the drawers according to the catalogue varantec system components Figure: Pattern light-gray, top with postforming edge, bow-type handles made of spring steel.

Size: 430 x 420 x 1000 mm (width x depth x height)



varantec®select basic cabinet

Individual cabinet with drawers of the wide-wall drawer system 2

Partitioning of the drawers as per the catalogue varantec system components Figure: Pattern maple, top with nicely shaped postforming edge, elegant segment handles, chromium-plated Size: 1260 x 420 x 1200 mm (width x depth x height)

varantec®pro and varantec®select Group 2: Sideboard system



varantec®pro sideboard with plastic sliding doors

Figure: Pattern light-gray, top with basic edge, bow-type handles light-blue RAL 5012, 1 adjustable shelf, suitable for accommodating 2 rows DIN A4, at the front 2 sliding doors inclusive lock
Size: 1220 x 400 x 780 mm (width x depth x height)



varantec select sideboard with horizontal roller shutters

Figure: Pattern maple, top with nicely shaped postforming edge, elegant segment handle chromium-plated, equipped with 3 shelves, roller shutters silver gray
Size: 860 x 400 x 780 mm (width x depth x height)



varantec®pro combination sideboard with glass sliding doors and a horizontal roller shutter system

Figure: Pattern maple, top with a nicely shaped postforming edge, bow-type handles chromium-plated.
Bottom sideboard:
equipped with 2 shelves, roller shutters silver gray
Size: 1820 x 600 x 1000 mm (width x depth x height)
Top sideboard:
equipped with 4 glass shelves (ESG), at the front glass sliding doors (ESG), 1 central partition wall
Size: 1820 x 400 x 1000 mm (width x depth x height)

varantec®pro and varantec®select Group 3: High-level cabinet system for laboratory and office

This group of cabinets can be equipped with drawers, wing doors and roller shutter systems. The doors are made of high-density fine chipboards with a structured, anti-dazzle plastic covering or alternatively made of glass (on request, toughened safety glass ESG deliverable). The standard height of the high-level cabinets is 2000 mm. With top cabinets and facings, the high-level cabinets can be extended to the ceiling.

Note:

The illustrated cabinet is part of the aluminium cabinet series varantec®select and its special feature is the additional aluminium system profile adapted to the outside.

1
Basic cabinet with 2 all-over wing doors and 2 aluminium profiles
Size: 1030 x 600 x 2000 mm
(width x depth x height)

2
Row cabinet with wing doors with 4/5 glazing inclusive all-around frame
Size: 1000 x 600 x 2000 mm
(width x depth x height)

3
Row cabinet with glass wing doors with full glazing inclusive all round frame
Size: 1000 x 600 x 2000 mm
(width x depth x height)

4
Row cabinet with glass wing doors with frameless full glazing
Size: 1000 x 600 x 2000 mm
(width x depth x height)



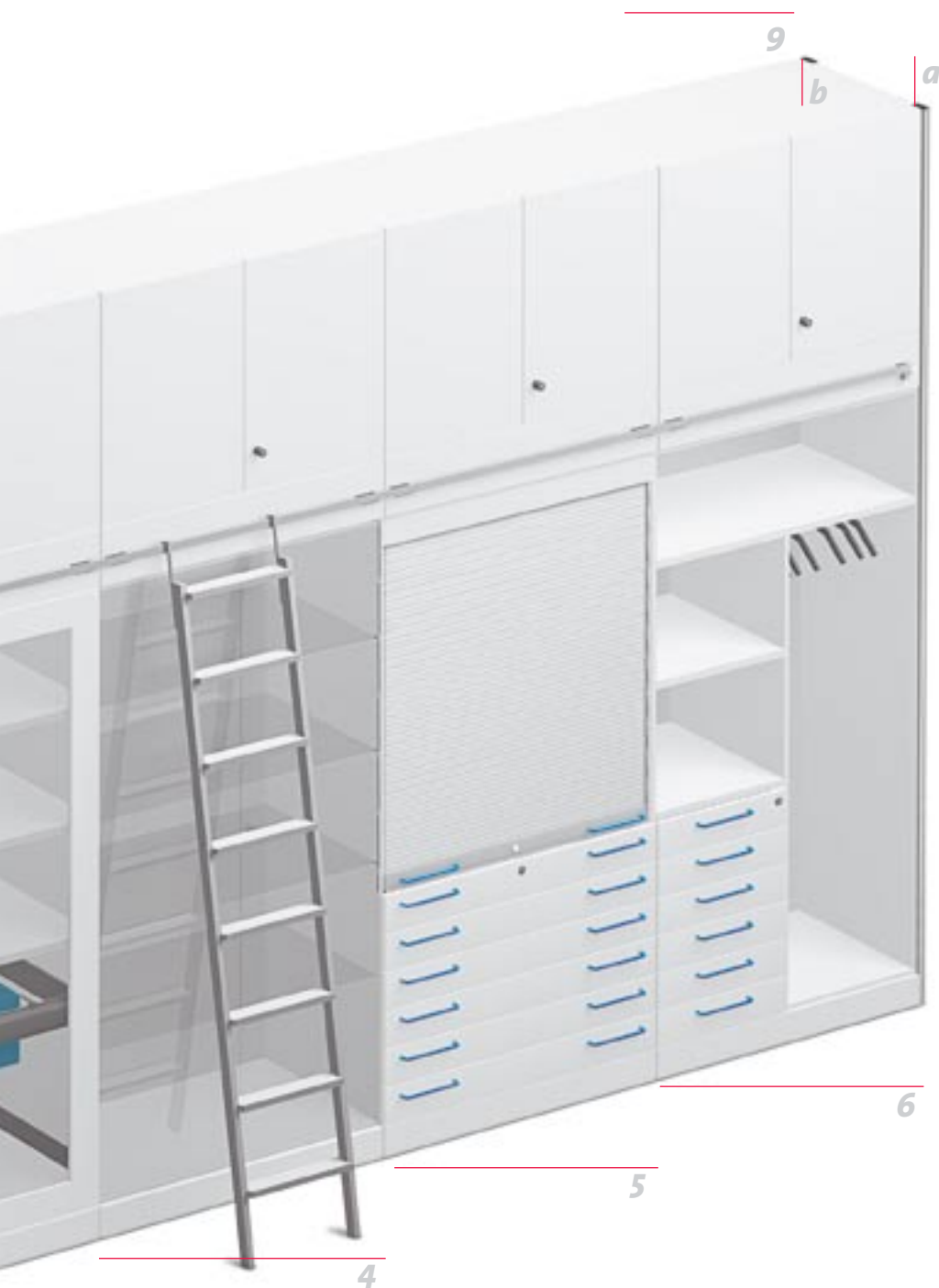

5
Row cabinet with roller shutters and drawers
 Size: 1000 x 600 x 2000 mm
 (width x depth x height)

6
Final row cabinet as open hall cupboard with 2 aluminium profiles
 (On request also with double doors at the front)
 Size: 1020 x 600 x 2000 mm
 (width x depth x height)

7
Top element as basic row cabinet with facing, 2 all-over wing doors and 2 aluminium profiles
 Size: 1030 x 600 x 900 mm
 (width x depth x height)

8
Top element as row cabinet with facing, 2 all-over wing doors
 Size: 1000 x 600 x 900 mm
 (width x depth x height)

9
Top element as final row cabinet with facing, 2 all-over wing doors and 2 aluminium profiles
 Size: 1020 x 600 x 900 mm
 (width x depth x height)

a
Aluminium profile at the front

b
Aluminium profile at the back

Note: The interior fittings of the cabinet correspond to the system components of the cabinet programme varantec®pro.

Integration of monitors in the working place

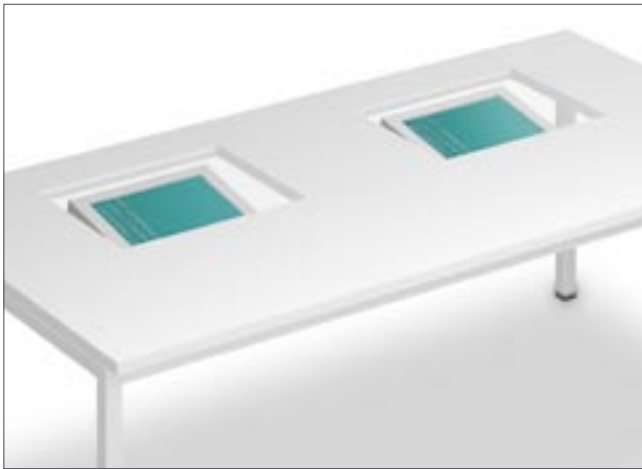

Embedded monitors with an integrated glass panel in the work top

Recommended depth of table: 1000 mm

Professional covering underneath the work top. The angle of vision is adjustable by a flexible support. High-quality, non-reflecting safety glass.

Design	Screen diagonal	Additional price per cutout/Order No.
Embedded monitor	17 Zoll	04.99.0001
	19 Zoll	04.99.0002
Embedded flat screen Monitor	17 Zoll	04.99.0003
	19 Zoll	04.99.0004



Swivel arm

Order No. 04.99.0005

- steplessly adjustable in height (gas spring supported)
- carrying power 5-20 kg
- with integrated keyboard support (withdrawable and lowerable) and rest for the ball of the thumb
- maximum depth of keyboard 255 mm
- cable insert system with torsion protection
- colour light-gray RAL 7035
- monitor support size (width x depth) 400 x 400 mm with cable feedthrough box, size (width x depth) 40 x 80 mm
- swivel length 790-980 mm (from basic axle to front edge of keyboard support)
- for direct plugging in the universal adapter



Monitor stage

Order No. 04.99.0006

- at the top, for placing on the monitor
- at the bottom, for keeping the keyboard
- sizes (width x depth x height)
 - 585 x 360 x 80 mm (outside)
 - 543 x 360 x 60 mm (inside)



Withdrawable keyboard support

Order No. 04.99.0007

- withdrawable for installation underneath the work top
- maximum weight of keyboard 6 kg
- colour black
- size (width x depth x height)
 - 600 x 253 x 56 mm (outside)
 - 555 x 250 x 54 mm (inside)



Keyboard clip

Order No. 04.99.0008

- for installation underneath the storage board or cockpit
- withdrawable by 200 mm and lowerable by 120 mm
- colour light-gray RAL 7035
- keyboard support with an integrated rest for the ball of the thumb size (width x depth) 406 x 280 mm
- maximum depth of keyboard 220 mm
- maximum height of keyboard 75 mm

Flat screen swivel arm

- The position of the swivel arm is individually adjustable (high degree of free space)
- suitable for flat screens 14 - 18 inch diagonal (corresponds to a weight of 2,5 - 8,5 kg without leg)
- covered cable guidance within the plastic covering
- The arm is rotating by maximum 360° and slewable to top and bottom by 0° - 90°
- optionally for direct plugging in the universal adapter or lateral clamping to the work top



For direct plugging in the universal adapter:
Order No.: 04.99.0009
For lateral clamping to the work top:
Order No.: 04.99.0010



Extension arm:
Order No.: 04.99.0011
Keyboard support:
Order No.: 04.99.0012

Mouse pad:
Order No.: 04.99.0013

Flat screen holder

Order No.: 04.99.0014

- ideally suited for adaptation to a horizontal aluminium rail
- suitable for flat screens of 14 - 18 inch diagonal (2,5 to 8,5 kg)
- excellent swivel and rotation range

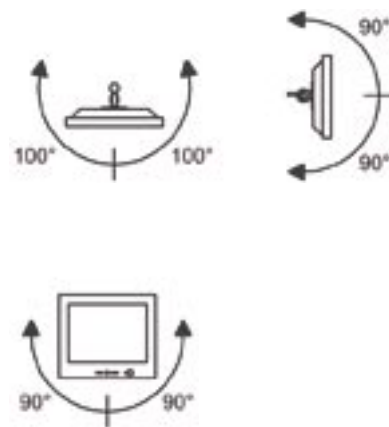
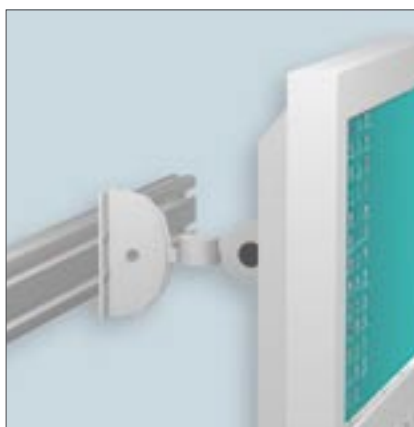

Horizontal aluminium rail

- for installation between the two rear aluminium leg system profiles
- steplessly adjustable in height, for installation of the above illustrated flat screen holder (Order No. 04.99.014)

Width of table	Order No.
1200 mm	04.99.0015
1600 mm	04.99.0016
1800 mm	04.99.0017
2000 mm	04.99.0018

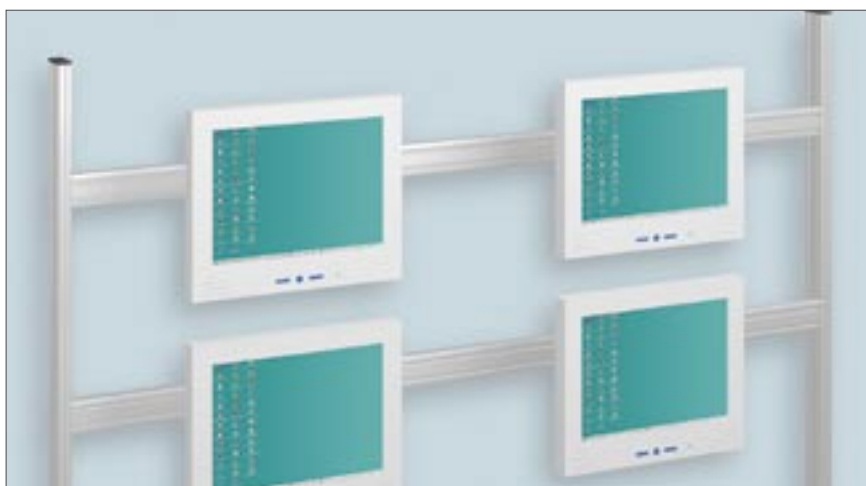

Accessories for the laboratory



Measuring line holder

Order No. 04.99.0020

Anodized aluminium rail, 300 mm long with 21 plastic supporting elements for up to 100 measuring lines, simple fastening to the wall



Triple hose holder

Order No. 04.99.0021

made of shock-proof plastic, simple fastening to the wall



Combined line holder

Order No. 04.99.0022

Consisting of a measuring line holder and a hose holder, fitted on a melamine laminated chipboard, simple fastening to the wall



Measuring line trolley type 1

Equipment:

- basic frame 800 x 500 x 1200 mm (width x depth x height)
- optionally 1500 mm high
- with 4 steering rollers \varnothing 75 mm, 2 of them fixable
- 2 laboratory cord holder 300 mm long with 21 supporting elements each
- at the front 1 triple hose holder
- at the back 1 storage tray

Order No. 04.99.0023 for 1200 mm height

Order No. 04.99.0024 for 1500 mm height



Measuring line trolley type 2

Equipment:

- basic frame 800 x 500 x 1200 mm (width x depth x height)
- optionally 1500 mm high
- with 4 steering rollers \varnothing 75 mm, 2 of them fixable
- board with boreholes for suspending 2 x 66 laboratory cords

Order No. 04.99.0025 for 1200 mm height

Order No. 04.99.0026 for 1500 mm height

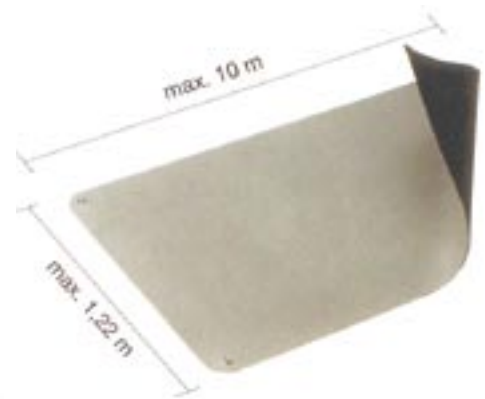

Soft PVC mats for table tops

available as fixed measurement or by the metre

Order No.

Size:

04.99.0027

600 x 1000 x 2 mm

04.99.0028

By the metre viz. price per metre inclusive costs for cutting. Maximum width 1,22 m length of roll 10,00 m

Note:

When ordering please indicate the exact dimensions, for example 0.4.99.0027 with 1,35 m x 1,00 m (selling price = list price x 1,35)



BNC cable

Cable: RG 58 C/U

Connector: double-sided BNC connector

Order No.	Design
H40.60A	BNC cable 25 cm
H40.60B	BNC cable 50 cm
H40.60C	BNC cable 100 cm



Testing spike with measuring line

Testing spike: with 4 mm lamellar plug

Cable: highly flexible 0,75 mm, double insulated

Length: 100 cm

Colour: red

Order No. H40.52A



A Quadropole pliers (1 pair)

Cable: 70 cm long

Pliers: electrically reciprocally isolated clamping jaws

Opening of pliers: max. 15 mm

Constant current: max. 0,5 A

Plug: 4 safety plugs

Order No. H40.54A



Laboratory cable

Cable: highly flexible silicone line

-50°C to +180° C, resistant against soldering iron

+300° C/10s

Connector: double-sided cascading connector

Socket parts -10°C to +80° C

Constant current: maximum 32 Amp.

Operating voltage: maximum 500 volt

Contact resistance: 0,3 mΩ

Order No.	Design
H40.50A	Laboratory cable 25 cm red
H40.50B	Laboratory cable 25 cm blue
H40.50C	Laboratory cable 25 cm black
H40.50D	Laboratory cable 50 cm red
H40.50E	Laboratory cable 50 cm blue
H40.50F	Laboratory cable 50 cm black
H40.50G	Laboratory cable 100 cm red
H40.50H	Laboratory cable 100 cm blue
H40.50K	Laboratory cable 100 cm black



Clamping spike

Clamping spike: with spring hook pair

Connection socket: for safety plug

Operating voltage: max. 1000 V AC/DC

Current: max. 1 A to 40° C

Total length: approx. 190 mm

(without safety plug)

Colour: red

Order No. H40.52B



Adapter bushing – red flexible cord

Safety clamping plug for flexible cords

Cord cross section: 0,12 mm² - 2,5 mm²

Order No. H40.56A



High-current clamping spike

Clamping spike: with claw gripper

Connection socket: for safety plug

Operating voltage: max. 1000 V

Current: max. 20 A to 40° C

Claw gripping width: max. 20 mm

Total length: approx. 130 mm (without safety plug)

Colour: black

Order No. H40.52C



Adapter bushing – black flexible cord

Safety clamping plug for flexible cords

Cord cross section: 0,12 mm² - 2,5 mm²

Order No. H40.56B



Safety short-circuit bar

with outputs for safety plugs at the back

Distance of pins: 19 mm

Temperature range: -10° C to +70° C

Constant current: max. 32 A

Order No. H40.58A



Adapter shockproof socket

Change-over from shockproof socket connection without protective conductor to 4 mm safety sockets

Order No. H40.56C



EGB Working place equipment

The EGB programme of accessories from erfi leaves nothing to be desired with respect to completion and retrofit. Some system components are required for the equipment of a modern EGB-conform working place. In particular the standards IEC 61340-5-1 and DIN IEC 47 (Sec) 1330 give information about the requirements of ESD working places and ESD protection zones.

Conductive working mats either of fixed dimensions or from a roll

- two-layer, hard-wearing synthetic rubber coating
- solder tin and heat resisting, abrasion-proof, halogen-free, volume conductive, conductive bonding is not required
- thickness of material: 2 mm
- discharge resistance RA as per EN 61340-5-1: $10^6 - 10^7 \Omega$

Order No.	Colour	Dimensions
04.99.0100	grey	From the roll: 1220 mm x 10 m
04.99.0101	grey	with rounded off corners, made with 2 press-studs 10 mm and 1 discharge cable, smooth (1 M Ω)

Width of roll 1.000 mm and pieces cut-to-size on request.

04.99.0102	green	From the roll: 1220 mm x 10 m
04.99.0103	green	with rounded off corners, made with 2 press-studs 10 mm and 1 discharge cable, smooth (1M Ω)

Width of roll 1.000 mm and pieces cut-to-size on request.

04.99.0104	beige	From the roll: 1220 mm x 10 m
04.99.0105	beige	600 x 1000 mm with rounded off corners, made with 2 press-studs 10 mm and 1 discharge cable, smooth (1 M Ω)

Width of roll 1.000 mm and pieces cut-to-size on request.

04.99.0106	light-blue	From the roll: 1220 mm x 10 m
04.99.0107	light-blue	600 x 1000 mm with rounded off corners, made with 2 press-studs 10 mm and 1 discharge cable, smooth (1 M Ω)

Width of roll 1.000 mm and pieces cut-to-size on request.



Conductive floor mats and working mats resp. of 2,5 mm thickness

- two-colour caoutchouc covering with dotted pattern
- discharge resistance of $RA < 10^6 \Omega$ as per EN 61340-5-1 with a smooth surface
- thickness of material 2,5 mm, hardly inflammable B1 as per DIN 4102, section 1
- floor mat and table mat of the same pattern (dust-gray, alternatively light-gray)
- inclusive 2 press-studs each and 1 discharge cable
- volume conductive, conductive bonding not required

Order No.	Colour	Dimensions	Type
04.99.0110	dust-gray	2000 x 1200 x 2,5mm	floor mat
04.99.0111	dust-gray	1000 x 600 x 2,5mm	table mat
04.99.0112	light-gray	2000 x 1200 x 2,5mm	floor mat
04.99.0113	light-gray	1000 x 600 x 2,5mm	table mat



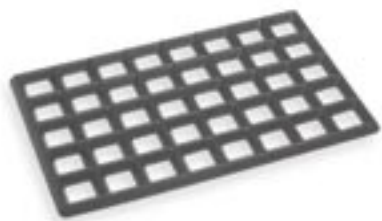

Solid rubber lattice mat

Mat for repairs and for manufacture/installation. Screws and nuts are caught due to the structure.

Order No.	Size	Conductive
04.99.0150	540 x 380 x 25 mm	no
04.99.0151	540 x 380 x 25 mm	yes
04.99.0152	625 x 375 x 20mm	no
04.99.0153	625 x 375 x 20mm	yes
04.99.0154	700 x 450 x 20mm	no
04.99.0155	700 x 450 x 20mm	yes



Earthing module

with integrated 1 MΩ protective resistor, shockproof earthing plug for connection to a shockproof socket, 6 x push-button connection 10 mm
Order No. 04.99.0160



Earthing module

with integrated 1 MΩ protective resistor for threaded fixing on or under the table, 1 x pin mounting box, 2 x push-button 10 mm
Order No. 04.99.01601



Safety wrist strap

with integrated 1 MΩ protective resistor with elastic, adjustable special tissue, anti-allergical. 4 mm push-button connection, suitable for connection to a spiral cable 04.99.0163
Order No. 04.99.0162



Spiral cable

with integrated 1 MΩ protective resistor at both sides with 4 mm push-button, for connection of the working mats with the safety wrist strap 04.99.0162
Order No. 04.99.0163



Spiral cable

with integrated 1 MΩ protective resistor, with 4 mm push-button and bush plug, for connection of the working mats with the earthing module 04.99.0161
Order No. 04.99.0164



Spiral cable

with integrated 1 MΩ protective resistor, with 4 mm push-button and 10 mm push-button, for connection of the working mats with the earthing module 04.99.0160
Order No. 04.99.0165

Examples of connection of spiral cables, earthing modules, working mats and wrist straps.



Spannfix articulated standing vise

Spannfix articulated standing vise

The clamping vise can be equipped with various components for the required application. It can be fastened to any work table of the series ABZ and varantec® without any problem.



Screw head

Technical data:

Clamping pressure: 150 kp
 Clamping width: 70 mm
 Clamping depth: 38 mm
 Width of jaw: 50 mm
 Jaws: plastic
 Weight: 0,60 kg
 Order No. 04.99.0200



Board holder

Fixable clamping width, any extension possible at any time, work-appropriate clamping by adjusting the central position, contact-proof support, tight clamping fit of printed circuit boards by a built-in spring system.

Order No. 04.99.0201



Covering plate for tipped frames

For the use with 04.99.0201. Covered with 20 mm foam material. Components of different sizes are so pressed-in that soldering is possible after turning. Size: 240 x 130 mm, Weight: 0,28 kg.

Order No. 04.99.0202



Universal clamping plate

Slots for current standardized screws for installing prototypes or for holding for example tuners, line transformers, loudspeakers etc. Weight: 0,10 kg.

Order No. 04.99.0203



Angle adapter

As accessory unit to be used for every working head, allows an even bigger turning circle. Weight: 0,08 kg.

Order No. 04.99.0204



Quick turning device

With a tightly connected angle adapter, allows very quick turning of the board holder with board and cover plate by 180°.

Weight: 0,25 kg.

Order No. 04.99.0205



Spannfix leg with ball joint

With clamp fixing to be screwed to a work table of a maximum thickness of the table top of 80 mm. Weight: 0,95 kg.

Order No. 04.99.0206



Spannfix leg with ball joint

With screw-type console and threaded tenon M 12 x 1,5 for screwing on. Base plate 150 x 105 mm. Weight: 0,80 kg.

Order No. 04.99.0207



Simple example for ordering:

04.99.0206 leg with ball joint

04.99.0204 angle adapter

04.99.0201 board holder

Programme of visitor chairs Leanos



Visitor chair L400

Four legs without arm rests, stackable,
height of back rest: 440 mm

Frame: steel pipe, black

Cloth cover: Numbers see page 85

Example of an order for the illustration opposite:

Order No.: L400 / 0232
Basic model / cover
Model L400 / 0232 Garant blue



Visitor chair L450

Four legs with rests, stackable,
height of back rest: 440 mm

Frame: steel pipe, black

Cloth cover: Numbers see page 85

Example of an order for the illustration opposite:

Order No.: L450 / 0232
Basic model / cover
Model L450 / 0232 Garant blue



Visitor chair L500

Four legs without arm rests, stackable,
height of back rest: 440 mm

Frame: steel pipe, black

Cloth cover: Numbers see page 85

Example of an order for the illustration opposite:

Order No.: L500 / 0232
Basic model / cover
Model L500 / 0232



Visitor chair L550

Four legs with arm rests, stackable,
height of back rest: 440 mm

Frame: steel pipe, black

Cloth cover: Numbers see page 85

Example of an order for the illustration opposite:

Order No.: L5500 / 0232
Basic model / cover
Model L550 / 0232 Garant blue

Programme of laboratory chairs Leanos



Swivel chair L101

Low back rest, **permanent contact mechanism**, back rest adjustable in height, basic adjustment of sitting height, height of back rest: 430 mm

Steel foot: black, on request brilliant silver or chromium-plated

Cloth cover: Numbers see page 85

Castors: soft, for hard floors Order index / 0
hard, for soft floors Order index / 1

Example of an order for the illustration opposite:

Order No.: L101 / 0232 / 1
Basic model / cover / type of castors
Model L101 / 0232 Garant blue / hard castors for soft floors



Swivel chair L102

Low back rest, **synchronous mechanism and regulation of weight**, back rest adjustable in height, basic adjustment of sitting height, height of back rest: 430 mm

Steel foot: black, on request brilliant silver or chromium-plated

Cloth cover: Numbers see page 85

Castors: soft, for hard floors Order index / 0
hard, for soft floors Order index / 1

Example of an order for the illustration opposite:

Order No.: L102 / 0232 / 1
Basic model / cover / type of castors
Model L102 / 0232 Garant blue / hard castors for soft floors



Swivel chair L151

High back rest, **permanent contact mechanism**, back rest adjustable in height, basic adjustment of sitting height, **height of back rest: 530 mm**

Steel foot: black, on request brilliant silver or chromium-plated

Cloth cover: Numbers see page 85

Castors: soft, for hard floors Order index / 0
hard, for soft floors Order index / 1

Example of an order for the illustration opposite:

Order No.: L151 / 0232 / 1
Basic model / cover / type of castors
Model L151 / 0232 Garant blue / hard castors for soft floors



Swivel chair L152

High back rest, **permanent contact mechanism**, back rest adjustable in height, basic adjustment of sitting height, **height of back rest: 530 mm**

Steel foot: black, on request brilliant silver or chromium-plated

Cloth cover: Numbers see page 85

Castors: soft, for hard floors Order index / 0
hard, for soft floors Order index / 1

Example of an order for the illustration opposite:

Order No.: L152 / 0232 / 1
Basic model / cover / type of castors
Model L152 / 0232 Garant blue / hard castors for soft floors



Option:
Arm rests (1 pair)
adjustable in width
and height, black,
Order No. L952



Option:
Ring arm rests
(1 pair) black
Order No. L950

Cloth covers for models Lenos

Cloth cover Nora



NO 13



NO 03



NO 14

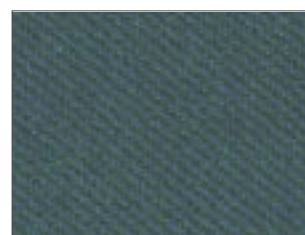

NO 04



NO 12

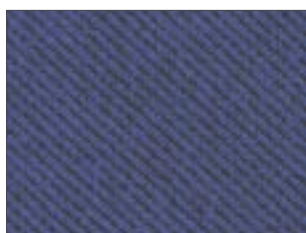

NO 02



NO 32

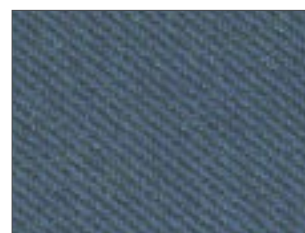

NO 22



NO 01



NO 11

Cloth cover Garant

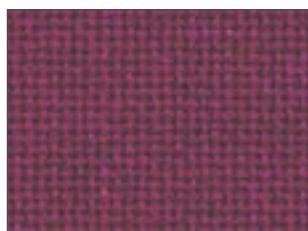

O223

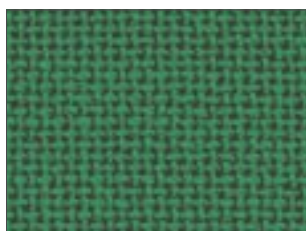

O234



O232



O222



O201

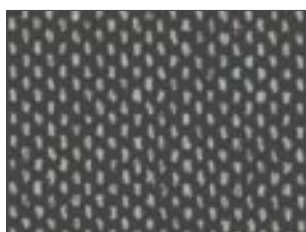

O241

Cloth cover Duotec MOS antistatic



9801



9802



9803



9811

Note: Deviations in colour due to the print are possible.

Programme of working chairs Sintec for the production



Model Sintec 9810-1000

Contact back rest and adjustment of the seat's inclination, seat and back rest made of shock-proof and break-proof polypropylene. Textile or integral foam upholstery possible. Height of back rest 420 mm. Adjustment of the sitting height from 430 - 580 mm. With abrasion-proof plastic floor gliders.
Order No. 9810-1000

Model Sintec 9803 -1000

same as model 9800-1000, however, with load-dependent braking double-casters for hard floors.
Order No. 9803-1000



Model Sintec 9801-1000

same as model 9800-1000, however, adjustment of sitting height from 580 - 850 mm. With abrasion-proof plastic floor gliders and an all-around climbing assistant.
Order No. 9801-1000

ESD chair



Model 9801E

Contact back rest. Adjustment of sitting height from 580 - 850 mm. Height of back rest 420 mm. With climbing assistant and gliders.
Order No. 9801E

Model 9800E

same as model 9801E, however, adjustment of sitting height from 530 - 580 mm. With gliders.
Order No. 9800E

Model 9803E

same as model 9801E, however, adjustment of sitting height from 430 - 580 mm. With castors.
Order No. 9803E



Ring arm rest
Order No. 9890-9900



Comfortable arm rest, adjustable in height
Order No. 9353-9900



Model 9865-2001

The integral foam upholstery allows a soft "sitting on an air cushion", is washable and easy to clean. It is resistant against slight acids and lyes. Colour blue.
Order No. 9865-2001



Model 9875

Soft textile upholstery consisting of hard-wearing cloth:
Colours are selectable
black: Order No. 9875-6801
grey: Order No. 9875-6811
blue: Order No. 9875-6802
red: Order No. 9875-6803



Model 9865E/2000

Conductive integral foam upholstery, easy to clean.
Colour: black.



Model 9875E/9801

Conductive textile upholstery, colour: black. Also upholstery 9811, 9802 or 9803 possible, see page 85, cloth cover Duotec MOS antistatic

Swivel Chair, swivel stool, standing assistants

Wooden swivel chair for classrooms



Model 9437-812-234

Adjustment of sitting height by a gas spring from 380 - 510 mm, revolving by 360°, seat and back rest made of multi-laminated beech wood, lacquered, natural-coloured. Sitting width: 415 mm, sitting depth: 390 mm, height of back rest: 280 mm, back rest flexible, five-leg base with plastic gliders, colour brilliant silver
Order No. 9437-812-234

with load-dependent, braking, soft safety double castors. (See figure).

Order No. 9437-801-234

Model 9437-801-234

same as model 9437-812,234, however,

Swivel stool



Model 9467-3000

Height adjustment by gas spring with a simple ring release from 460 - 630 mm. Specially large seat, Ø 400 mm, made of multi-laminated beech wood, lacquered, natural-coloured. With abrasion-proof plastic gliders.
Order No. 9467-3000

Model 9468-3000

same as model 9467-3000, however, with load-dependent, braking double-castors for hard floors.

Order No. 9468-3000

Model 9469-3000

same as model 9467-3000, however, height adjustment of seat from 570 - 850 mm.

With abrasion-proof plastic floor gliders and foot ring.

Order No. 9469-3000

Standing assistant



Model 9454-2000

Standing assistant with height adjustment of the seat by a gas spring from 650 - 850 mm. Seat made of integral foam, inclination to the adjustable by 10°. Integrated carrying handle. The seat is revolving by 360°. Solid, extremely flat base plate, Ø 470 mm. Metal parts coated with epoxy resin, anthracite.

Order No. 9454-2000, not conductive

Order No. 9454E-2000, conductive



Standing assistant



Model 9452-2000

Space-saving, foldable compact standing assistant made of precision steel pipe. Height adjustment of the seat from 650 - 850 mm by a grid mechanism. The seat is adjustable in inclination to the front by 10°. Seat made of integral foam with integrated carrying handle. Metal parts coated with epoxy resin, anthracite.

Order No. 9452-2000

Index A-Z

A		
A4 attachments	43	
A4 cockpits	43	
ABZ assembly- assembly working places	8-9,50-62	
ABZ didactic- working places for training	6-7,66-71	
ABZ laboratory working place system	4-5,40-49	
ABZ lifeline - height adjustable work tops	46	
ABZ lock – electronic locking system	20-21	
AC module (acto programme)	32	
AC supplies single-phase (acto programme)	31	
Active light grid	28	
acto insert board programme	30-39	
Adapter bushes – cord	79	
Adapter shockproof sockets	79	
Aluminium cabinets varantec select	72-75	
Aluminium energy channel system,vertical	62	
Aluminium leg system profile	22-24	
Aluminium profile, adaptable at the back	22-24	
Aluminium rise-and-fall pendant	52	
Aluminium swivel lamp	51	
Aluminium working place lamp	52	
Angle adapter	82	
Angular combination	14-15	
Anti-dazzle lighting	28	
Antistatic working places	10-15	
Articulated standing vise	82	
Assembly extension arm	50	
Assembly tables	8-9, 46, 50-62	
Assembly trolley	47	
Attachment cabinets	74-75	
Attachments 19”/3 HE up to 6 HE	42	
Attachments DIN A4	43	
Attachments	40-45	
B		
Balancer	51	
Basic cabinet	74	
Basic cabinets	72	
Basic swivel arm	57	
Basic system components	10-29	
BNC cable	79	
Board holder	82	
Bottle holdere	60	
Bowls	55	
Bus coupler field (acto programme)	38	
C		
Cabel chambers	23	
Cabel holder	59	
Cabinet systems	72-75	
Cabinet with drawers and glass wing doors	74-75	
Cabinet with roll shutters	73	
Cabinet with sliding doors	73	
Cabinet with wing doors	74-75	
Cabinets with drawers	12	
Cabinets with glass wing doors	73-75	
Cable channel system	23, 61	
Cable roll holder	60	
Cable troughs, built underneath	61	
Case shelves	55	
Cases	55	
Central protection	66	
Chairs	83-87	
Circular buffer plate 360° for small parts	27	
Clamping spike	79	
Clamping technique for height adjustment	46	
Clips profile for aluminium system profile	23	
Cloth covers for laboratory chairs	85	
CMOS processing (EGB/ESD tables)	11-13, 80-81	
Cockpits 19”/3HE to 6HE, straight and inclined	44	
Cockpits DIN A4	43	
Colours of aluminium leg system profiles	22	
Combination line holders	78	
Combination of highlight and sensolight	28-29	
Combination sideboards	73	
Combination tables	14-15	
Compartment dividers	18	
Complementary swivel arm	57	
Compressed air coupling with extension arm	51	
Compressed air outlet (acto programme)	38	
Compressed air supply rail	50	
Conductive drawer units	16-17	
Conductive floor mats	80	
Conductive storage boards	25	
Conductive working mats	80	
Conductive working tops	11-15	
Connection air-operated tools	51	
Constant voltage supply (acto programme)	34	
Contactless switching erfi sensolight	29	
Continuity tester (acto programme)	39	
Control module for foldaway tables	66	
Corner combinations	14-15	
Cover plate for equipped frames	82	
Cup holder	60	
D		
Data sockets (acto programme)	39	
Daylight regulation, erfi sensolight technique	29	
DC supplies (acto programme)	34-35	
Desks	12-13	
Device attachments 19”/3HE up to 6HE	42	
Device cockpits 19”/3HE up to 6HE	44-45	
Device insert technique 19”	42-45	
Device platform	27	
Device rack 19”	71	
Didactic systems components	63-71	
Dimmer function erfi-sensolight	29	
DIN A4 and DIN A3 – information chart	59	
DIN A4 attachments	43	
DIN A4 cockpits	43	
DIN A4 experiment frames	63-65	
Displaceable DIN A4 experiment frames	65	
Dividers	18	
Dividers	19	
Drawer inserts	19	
Drawer unit on rollers	17	
E		
Earthing modules	81	
EGB/ESD work tables (conductive)	12-13	
EGB/ESD working place accessories	80-81	
EGB/ESD working place equipment	80-81	
Electric energy supply for assembly tables	61-62	
Electric motorised foldaway tables	66-67	
Electric motorised height adjustment	46	
Electric motorised swivel tables	68-69	
Electronic laboratory	4-5	
Electronic lamp ballast	28	
Electronic locking system ABZ-lock	20-21	
Embedded monitor (flat screen holder)	76	
Empty panels (acto programme)	39	
Energy and auxiliary devices (acto programme)	30-39	
Energy attachment / energy cockpit	41	
Energy insert board programme acto®	30-39	
Energy saving (sensolight step 2 and 3)	29	
Energy swivel attachments	68-69	
Equipment for training	6-7, 66-71	
erfi sensolight® sensor-controlled lighting system	29	
Ergonomic assembly working places	46	
ESD chairs	84-86	
ESD working tables (conductive)	11-13	
Experiment frames DIN A4	63-65	
Extension arm for flat screen swivel arm	77	
F		
Fan lamp	53	
Filing cabinets	72-75	
Flat screen holder	77	
Flat screen swivel arm	77	
Floor mats	80	
Foil holders	59	
Foldaway tables by electric motor	66-67	
Foot rests	60	
Four-pole pliers	79	
Frameless all-over glass doors	75	
Front heights of drawers	16-17	
Full pull of drawers	17	
Functional generators (acto programme)	36	
G		
Group working places	70	
H		
Height adjustable working tables	46	
Height adjustable working tables	46	
Height adjustment by electric motor	46	
Height adjustment by means of a crank	46	
High-current clamping spike	79	
High-level cabinets	74-75	
highlight – innovative lighting system	28	
highlink® - LabVIEW device driver	37	
highlink® - software	37	
Holder for visual stock boxes	58	
Holder rails for flat screens, horizontal	77	
Holders for bowls, cases, tongues	55	
Holders for visual stock boxes	56-57	
Holding rail for visual stock boxes	56	
Hook for accessories	60	
Hook for perforated sheet metal wall	54	
Horizontal aluminium holder for flat screens	77	
Horizontal aluminium support for bowls etc.	55	
Horizontal supports for multiple connector strips	61	
Hose holder for perforated sheet metal wall	54	
Hose holder for wall mounting	78	
I		
Inclined 19” device cockpit	44-45	
Inclined storage plate for visual stock boxes	58	
Index	88-89	
Individual cabinet with drawers	72	
Individual drawer pulls	16-17	
Individual release module	66	
Individual working place lamps	53	
Information chart	59	
Insert board programme acto®	30-39	
Insert suspended frames	18	
Integration of monitors and flat screen	76	
Interface panels (acto programme)	39	
Interior equipment of cabinets	75	
Island working places for training centres	70	
K		
Keyboard clamp	76	
Keyboard holder for table top	76	
Keyboard support for flat screen swivel arm	77	
L		
Laboratory cabinets	72-75	



Ernst Fischer GmbH + Co. KG

Laboratory and workplace systems

Measuring devices

Test systems

Alte Poststraße 8

P.O. Box 308/309

D-72233 Freudenstadt/Germany

Phone +49 (0)7441 9144-0

Facsimile +49 (0)7441 9144-77

Internet www.erfi.de

e-Mail erfi@erfi.de